

<p>IPPUC INSTITUTO DE PESQUISA E PLANEJAMENTO URBANO DE CURITIBA</p>		<p>ORÇAMENTO - PARQUE LINEAR DE CAÇADOR - TRECHO 01</p>	
<p>Representante Técnico</p>	<p>ÁREA</p>	<p>INDICAÇÃO</p>	<p>DATA</p>
<p>EXERCÍCIO SOCIAL - CDA 4514-0</p>	<p>1200</p>	<p>PARQUE LINEAR DE CAÇADOR - EXPERIMENTAIS SEMPRE TENDENTES</p>	<p>01/17</p>
<p>Projeto - Urbanização de Parques e Praças</p>	<p>1200</p>	<p>1200</p>	<p>12 maio 2016</p>

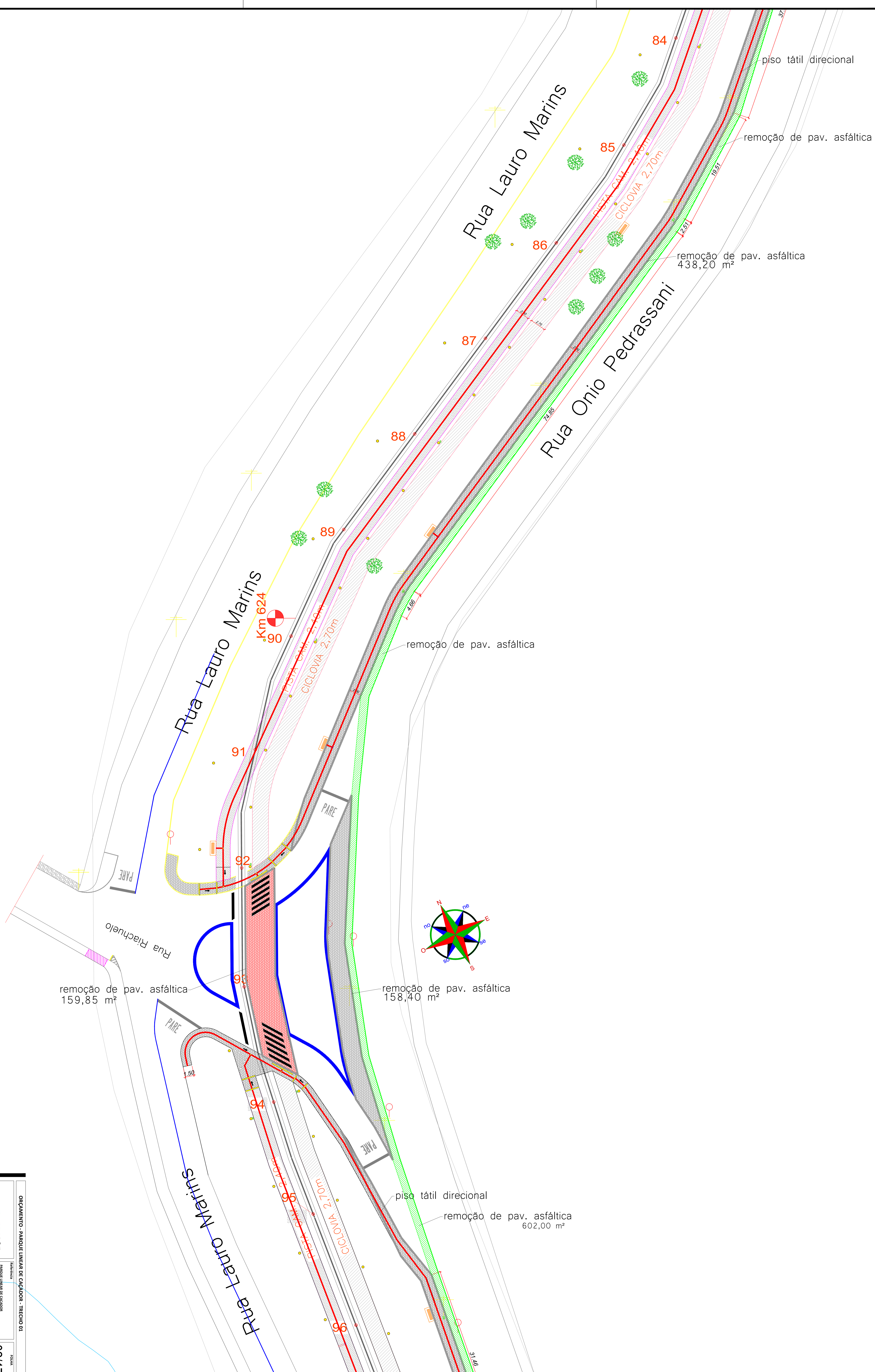

IPPUC
INSTITUTO DE PESQUISA E PLANEJAMENTO URBANO DE CAÇADOR

ORÇAMENTO - PARQUE LINEAR DE CAÇADOR - TRECHO 01

Representante Técnico	Assessor	Projeto	Assinatura
Área	INDICADA	INDICADA	INDICADA
Escala	1:200	INDICADA	INDICADA
Descrição	INDICADA	INDICADA	INDICADA
Arquivo	INDICADA	INDICADA	INDICADA

PARQUE LINEAR DE CAÇADOR
EXPERIMENTAIS SEMPRE
TIREMOS

DATA: 12 maio 2020

02/17

103,970

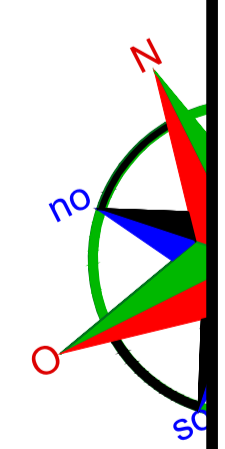
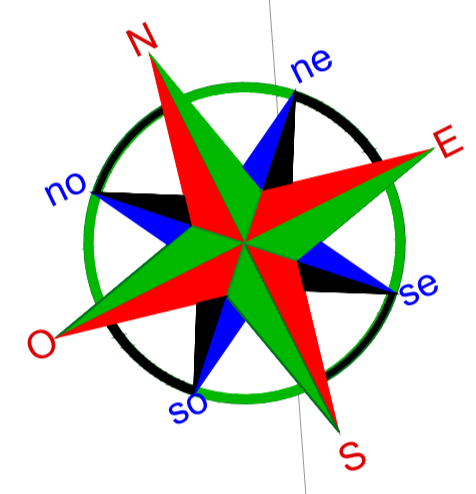
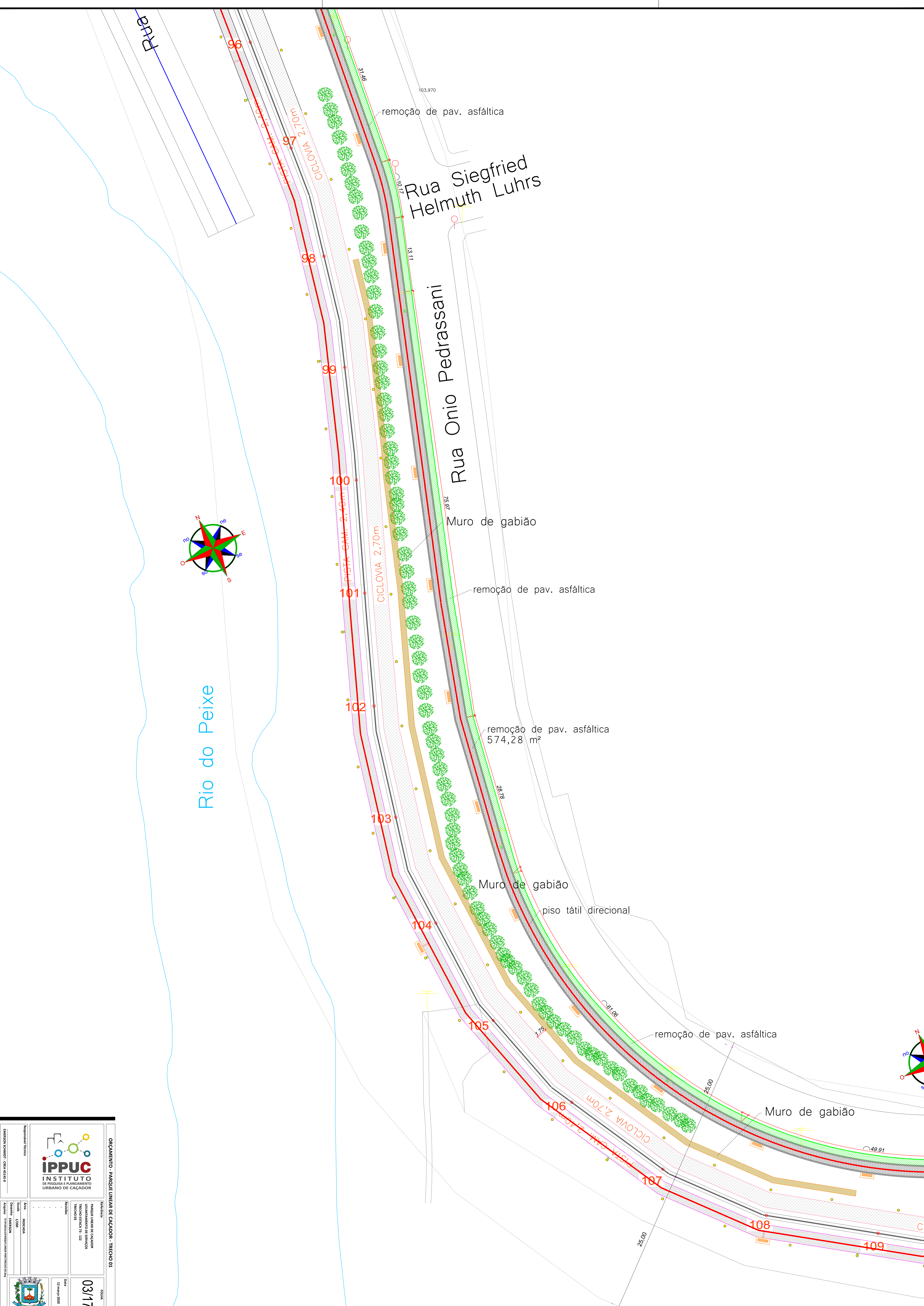

<p>IPPUC INSTITUTO DE PESQUISA E PLANEJAMENTO URBANO DE CAÇADOR</p>		<p>ORÇAMENTO - PARQUE LINEAR DE CAÇADOR - TRECHO 01</p>	
<p>Representante Técnico</p> <p>EXERCÍCIO SCHMIDT - CREA 45154-D</p>	<p>ÁREA</p> <p>ESTADO - RS</p> <p>ESPECIALIDADE - URBANISMO</p>	<p>INDICAÇÃO</p> <p>PARQUE LINEAR DE CAÇADOR</p> <p>EXERCÍCIOS SCHMIDT</p> <p>TRECHO 01</p>	<p>DATA</p> <p>12 maio 2020</p> <p>03/17</p>

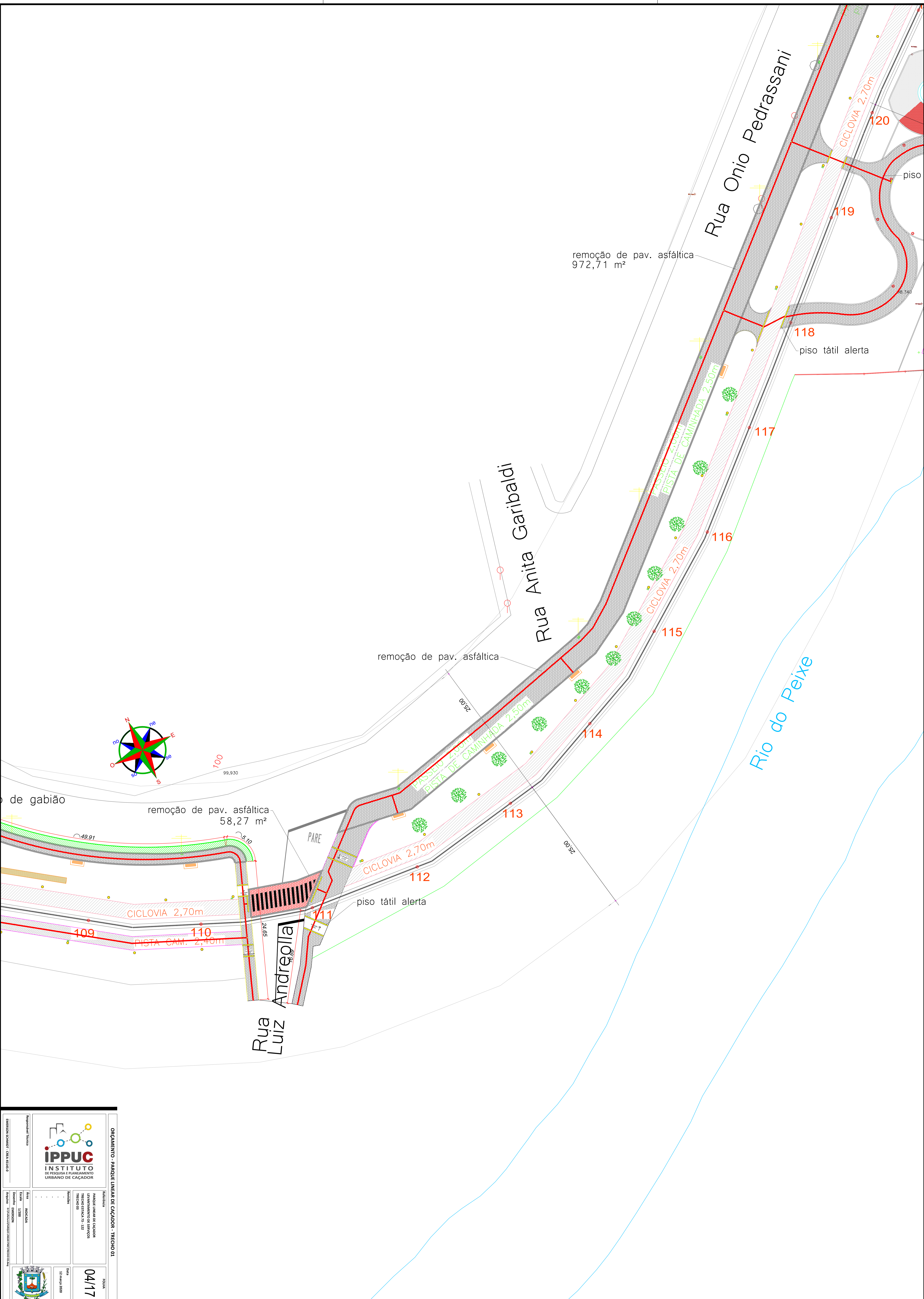

IPPUC
INSTITUTO DE PESQUISA E PLANEJAMENTO URBANO DE CAÇADOR

ORÇAMENTO - PARQUE LINEAR DE CAÇADOR - TRECHO 01

Representante Técnico	ÁREA	INDICAÇÃO	DATA
EXERCÍCIO SOCIAL - CDA 4515-0	12,00	PARQUE LINEAR DE CAÇADOR - EXPERIMENTAIS SEMPRE	04/17
		TRECHO 01	12 maio 2016

Projeto: 12,00

Arquivo: 12 maio 2016

ESTACA 73

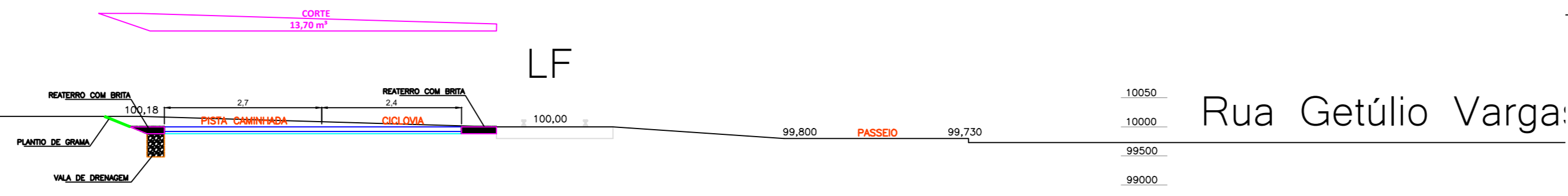

ESTACA 74

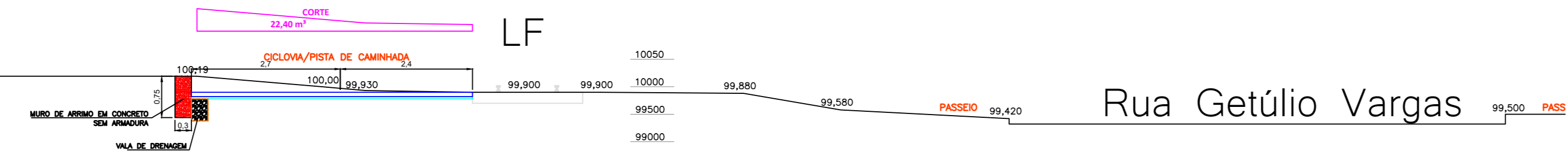

ESTACA 75

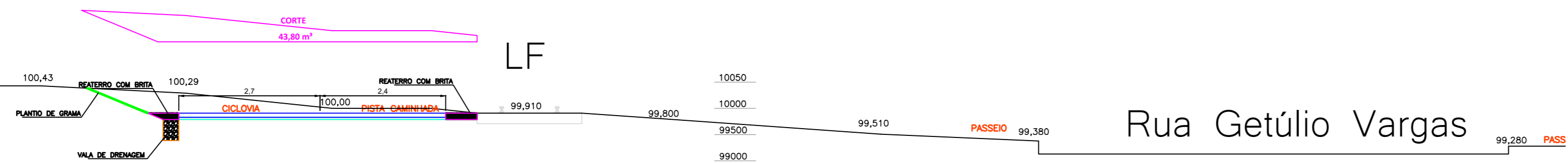

ESTACA 76

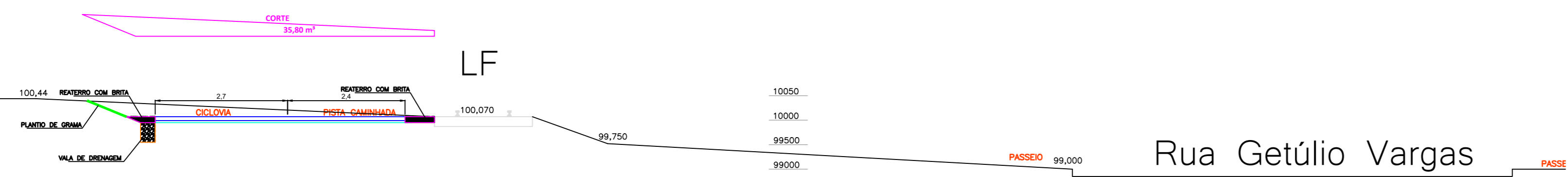

ESTACA 77

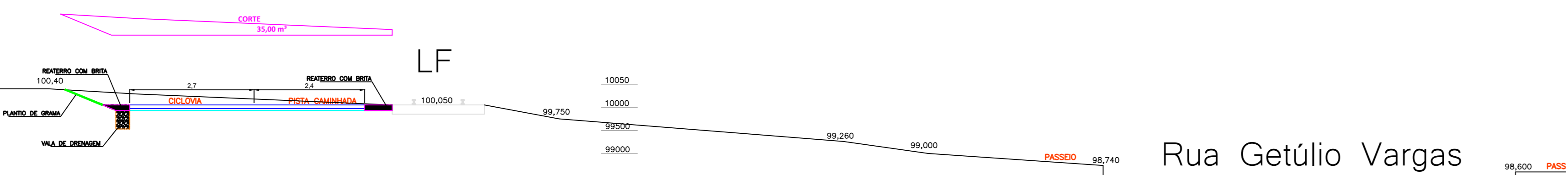

ESTACA 78

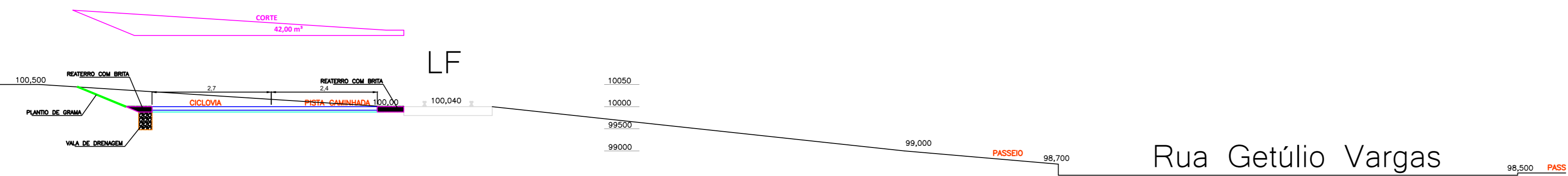

Rua Anita Garibaldi

ESTACA 79

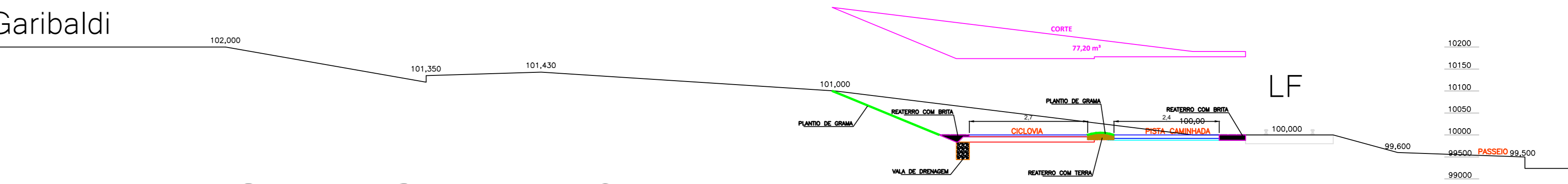

ESTACA 80

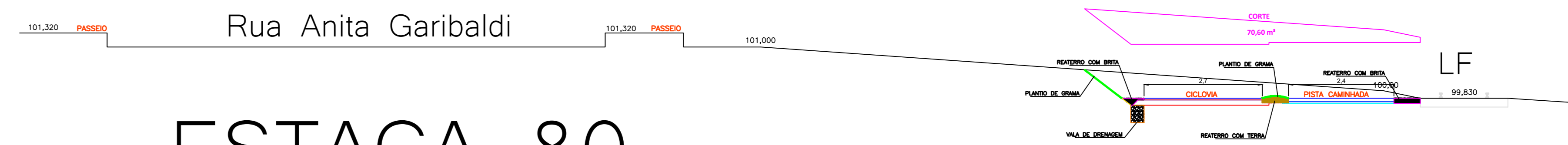

ESTACA 81

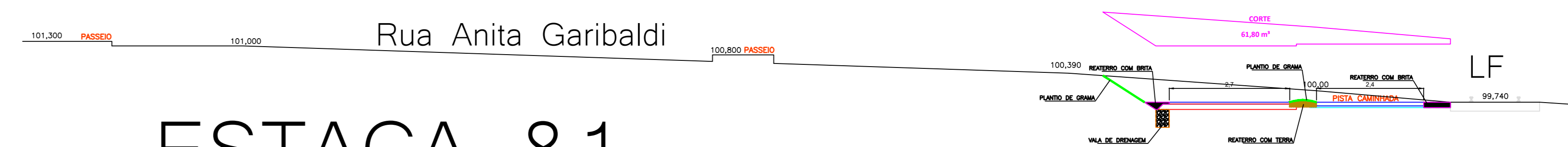

ESTACA 82

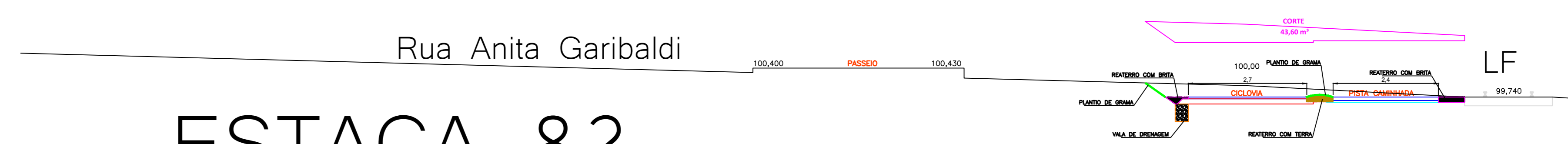

ESTACA 83

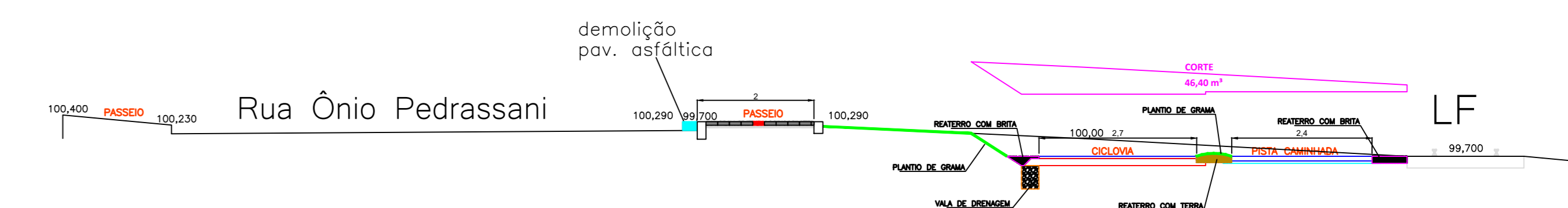

		Projeto ORÇAMENTO - PARQUE LINEAR - TRECHO 01	
Referência: PARQUE LINEAR DE CAÇADOR LEVANTAMENTO DE SERVIÇOS TRECHO ESTACA 73 - 122 TRECHO - 03		FOLHA 06/17	
Responsável Técnico EMERSON SCHMIDT - CREA 45145-D		Data 12 março 2020	
Escala 1/75		Área	
Desenho EMERSON		Arquivo D:\Instituto\PARQUE LINEAR\PARQUE LINEAR TRECHO 3.dwg	

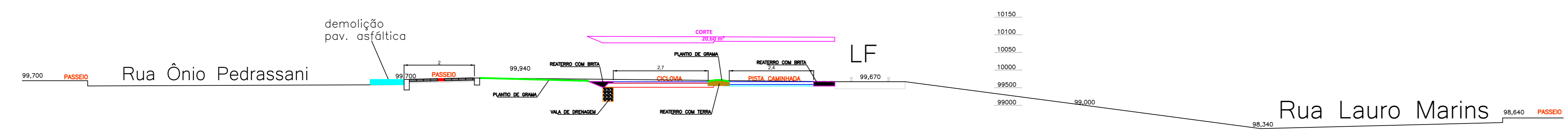

ESTACA 84

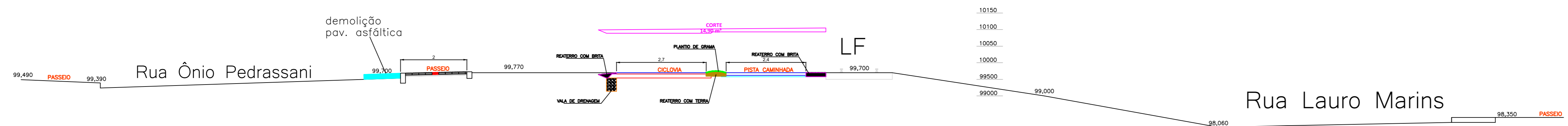

ESTACA 85

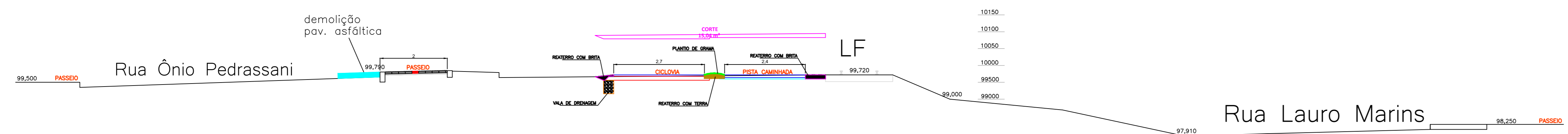

ESTACA 86

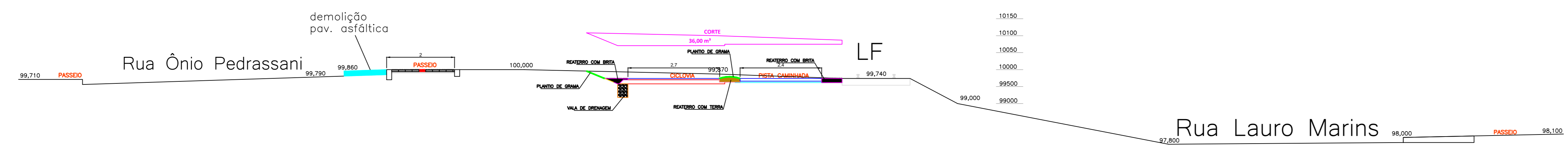

ESTACA 87

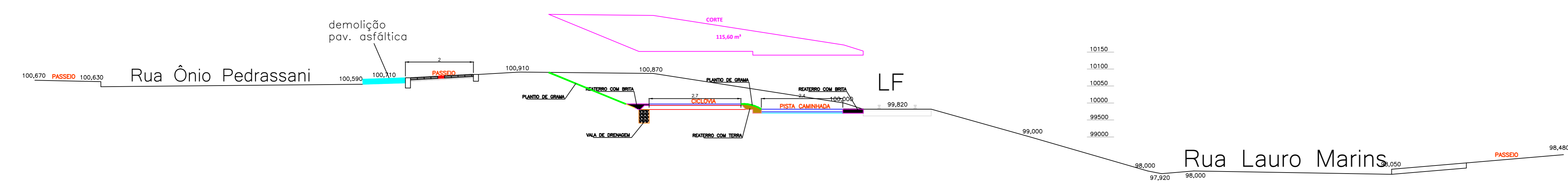

ESTACA 88

Projeto: ORÇAMENTO - PARQUE LINEAR - TRECHO 01		Referência: PARQUE LINEAR DE CAÇADOR LEVANTAMENTO DE SERVIÇOS TRECHO ESTACA 73 - 122 TRECHO - 03	FOLHA 07/17
		Revisões: REVISÃO DO PROJETO - - -	Data: 12 março 2020
Responsável Técnico: EMERSON SCHMIDT - CREA 45145-D		Área: Escala: 1/75 Desenho: EMERSON	
Arquivo: D:\urbanismo\PARQUE LINEAR FMS\Capas\TRECHO 1.dwg			

ESTACA 89

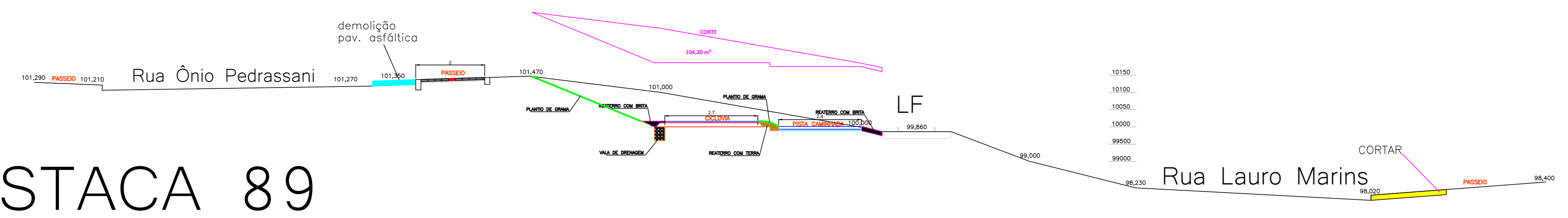

ESTACA 90

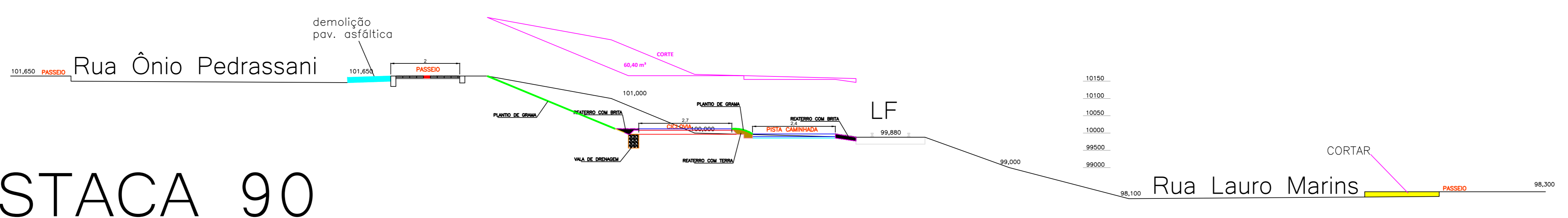

ESTACA 91

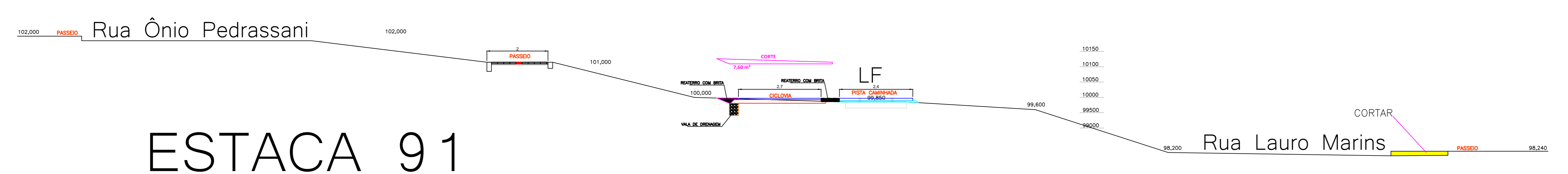

ESTACA 92

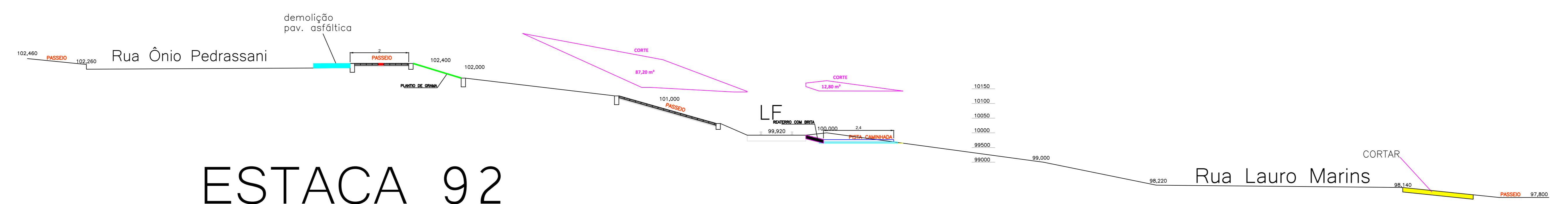

ESTACA 93

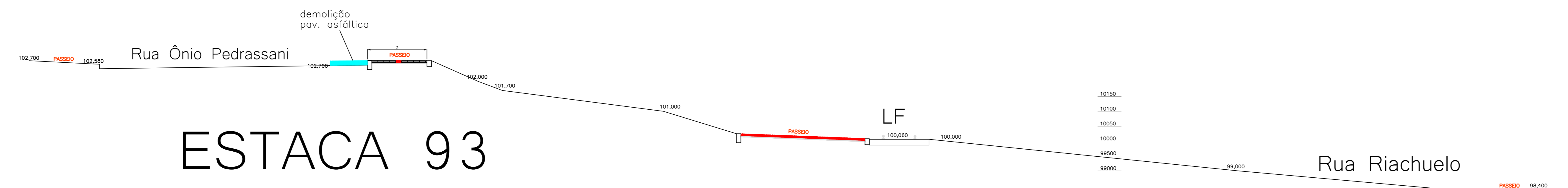

ESTACA 94

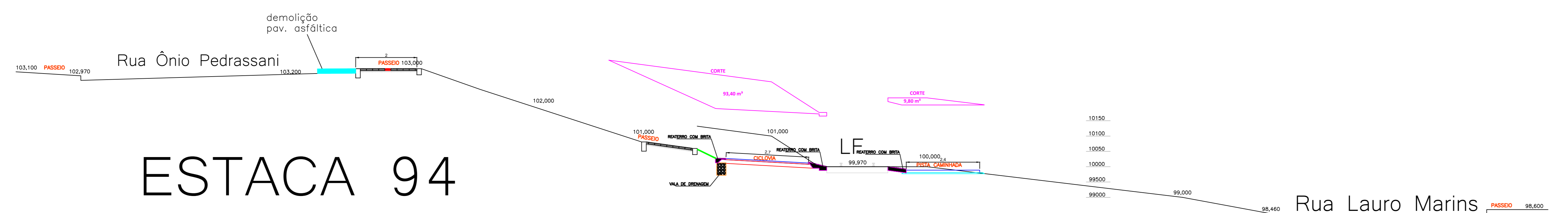

Projeto ORÇAMENTO - PARQUE LINEAR - TRECHO 01		FOLHA	
		08/17	
Referência: PARQUE LINEAR DE CAÇADOR LEVANTAMENTO DE SERVIÇOS TRECHO ESTACA 73 - 122 TRECHO - 03		Data: 12 março 2020	
Revisões: REVISÃO DO PROJETO			
Área		Escala	
1/75		EMERSON	
Desenho		Arquivo	
EMERSON SCHMIDT - CREA 45145-0		D:\Instituto\PARQUE LINEAR\FMS\Capas\TRECHO 3.dwg	

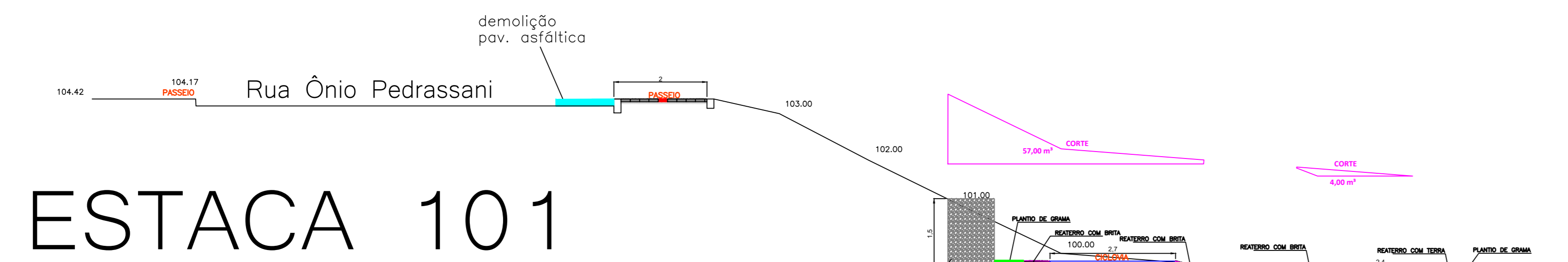

ESTACA 101

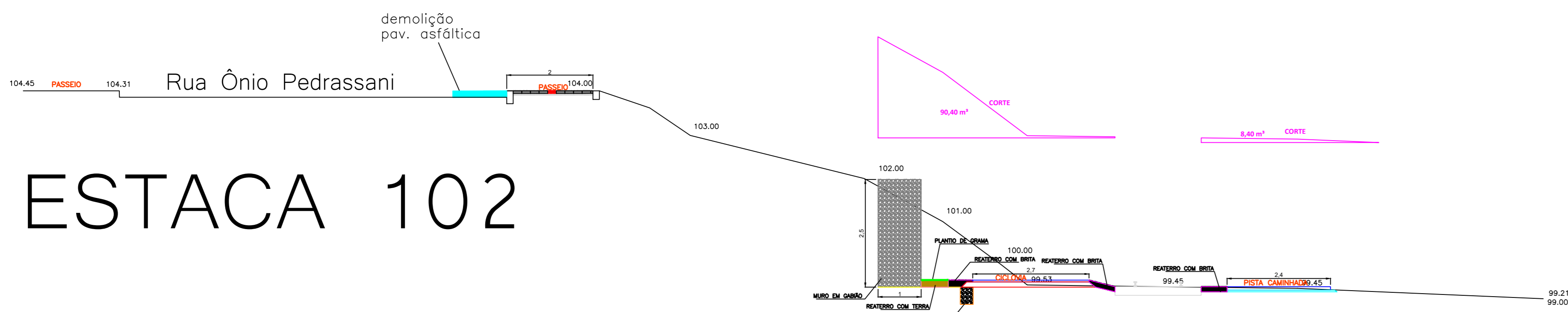

ESTACA 102

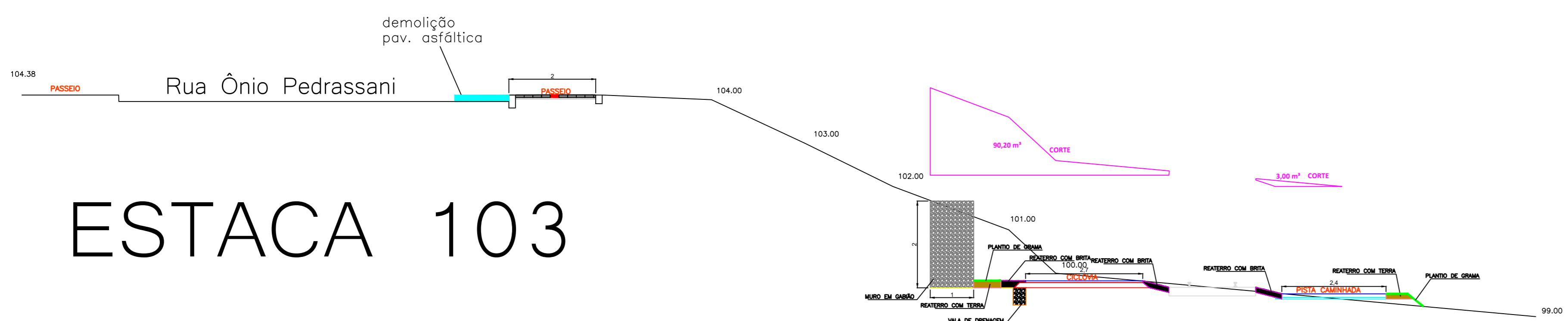

ESTACA 103

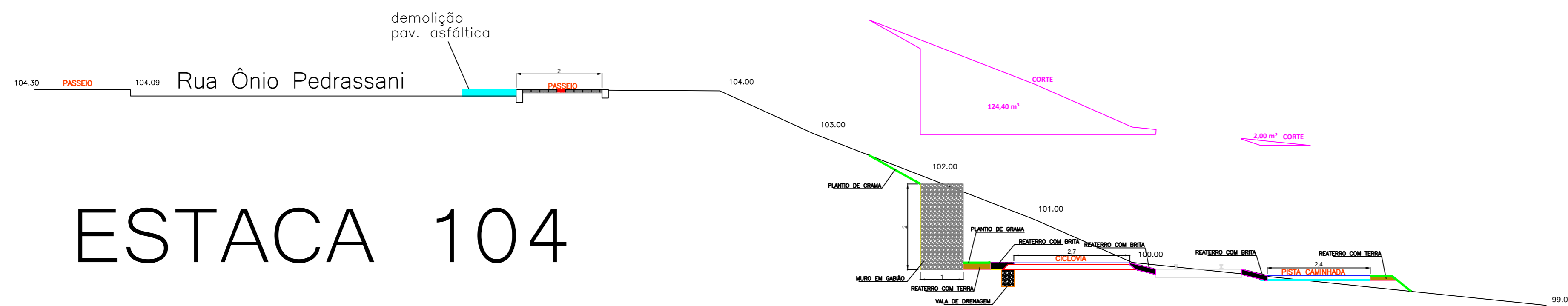

ESTACA 104

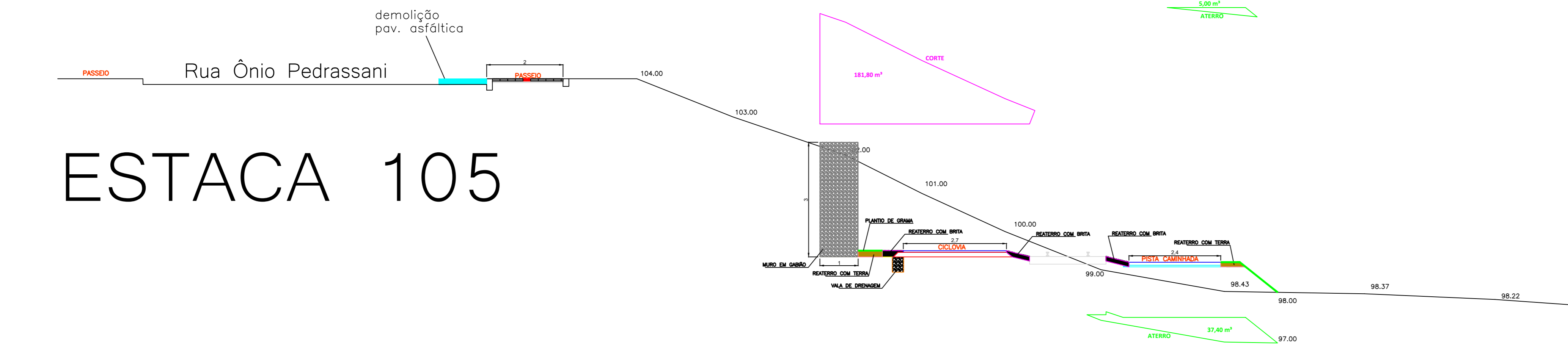

ESTACA 105

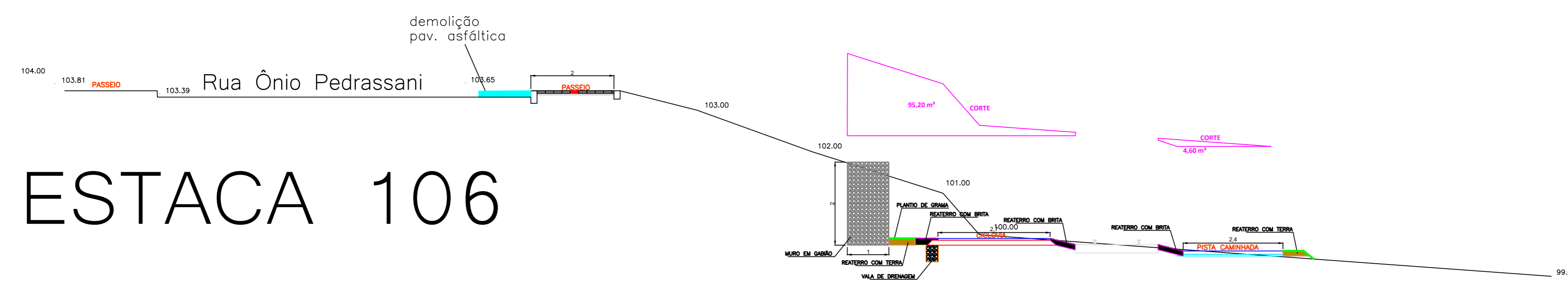

ESTACA 106

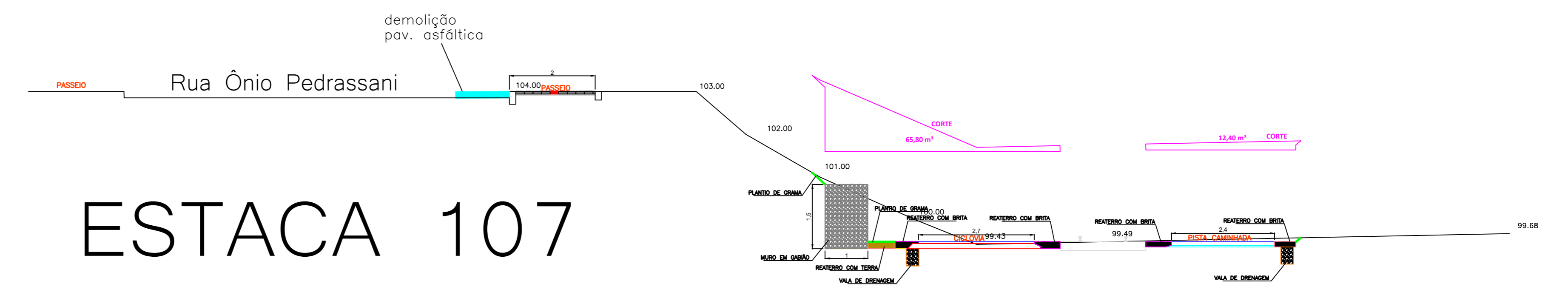

ESTACA 107

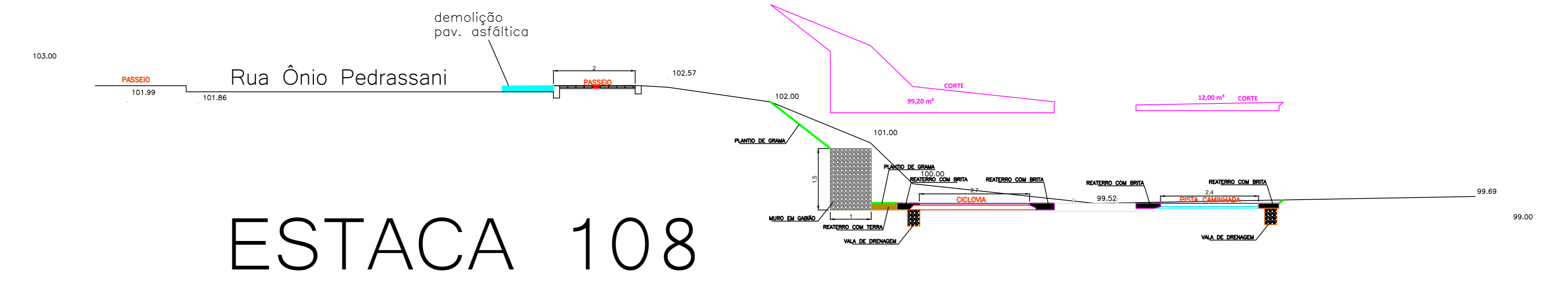

ESTACA 108

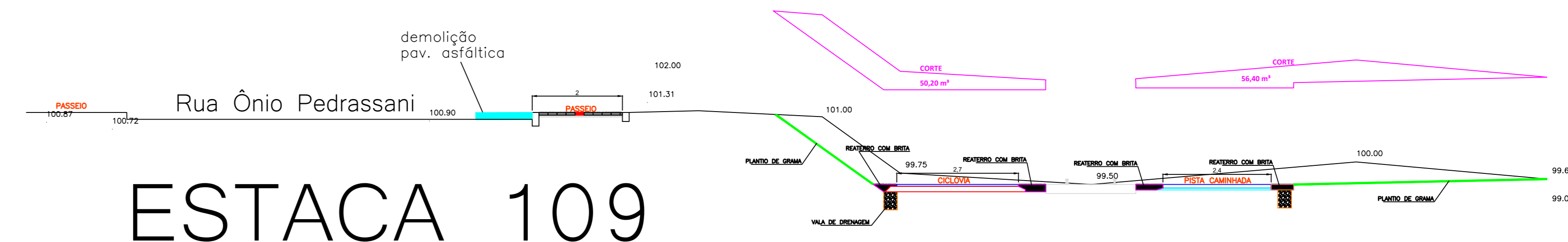

ESTACA 109

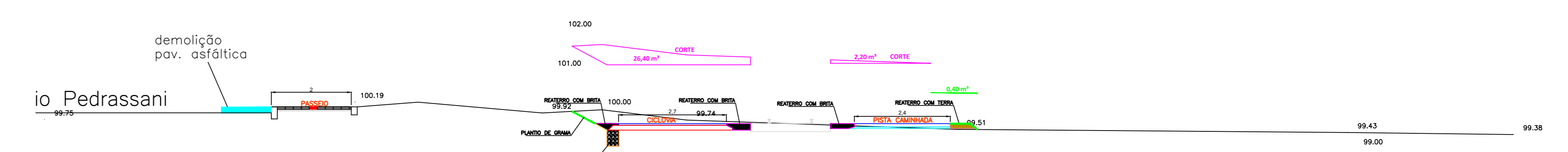

ESTACA 110

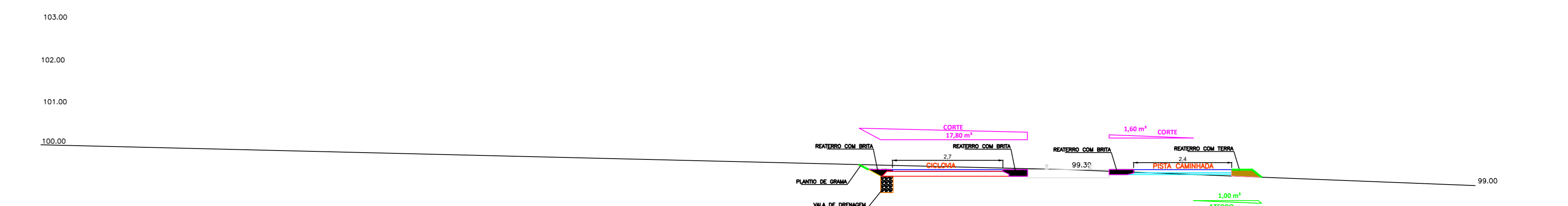

ESTACA 111

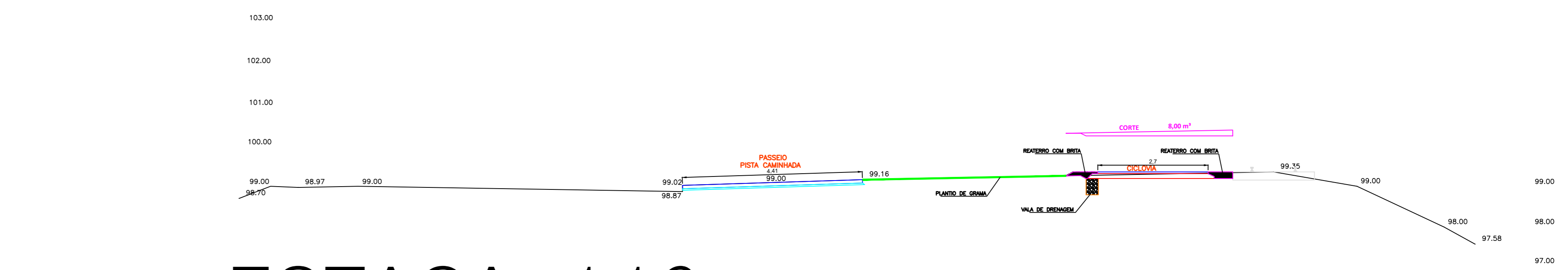

ESTACA 112

<p>Projeto ORÇAMENTO - PARQUE LINEAR - TRECHO 01</p>		<p>FOLHA</p>	
<p>Referência PARQUE LINEAR DE CAÇADOR LEVANTAMENTO DE SERVIÇOS TRECHO ESTACA 73 - 122 TRECHO - 03</p>		<p>10/17</p>	
<p>Revisões</p> <p>REVISÃO DO PROJETO</p> <ul style="list-style-type: none"> - - - 		<p>Data</p> <p>12 março 2020</p>	
<p>Responsável Técnico</p> <p>EMERSON SCHMIDT - CREA 45145-D</p>		<p>Área</p> <p>Escala 1/75</p> <p>Desenho EMERSON</p> <p>Arquivo D:\Projeto\PARQUE LINEAR FMS\Capas\TRECHO 3.dwg</p>	

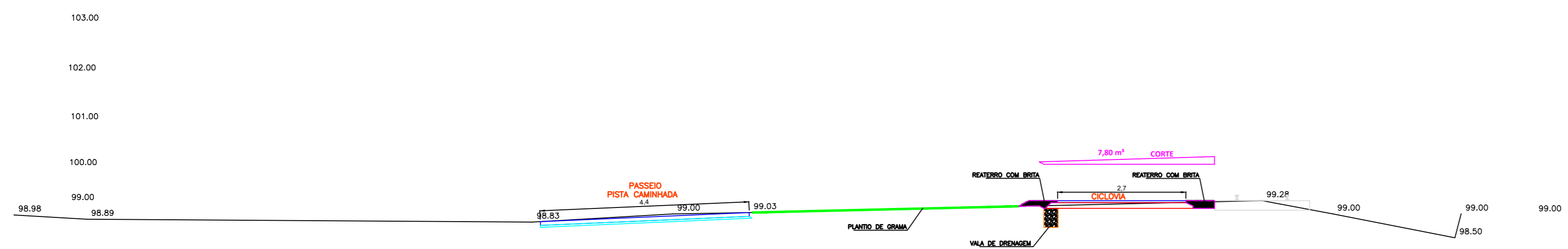

ESTACA 113

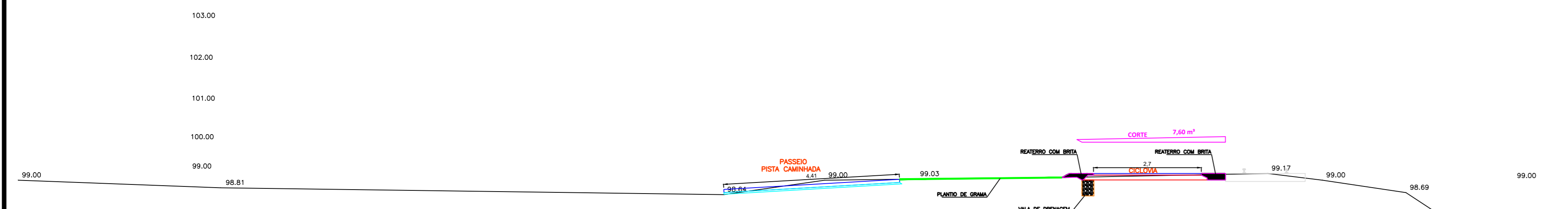

ESTACA 114+00

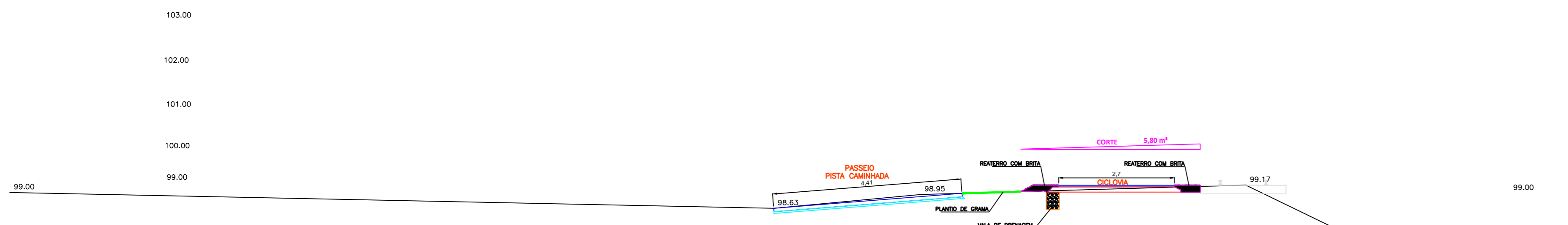

ESTACA 115

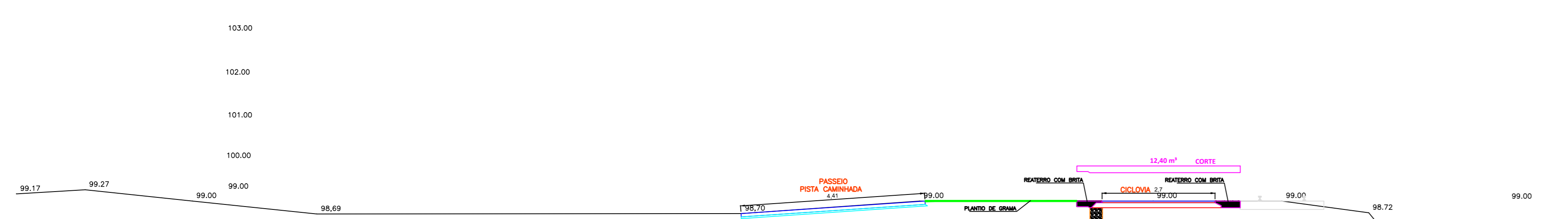

ESTACA 116

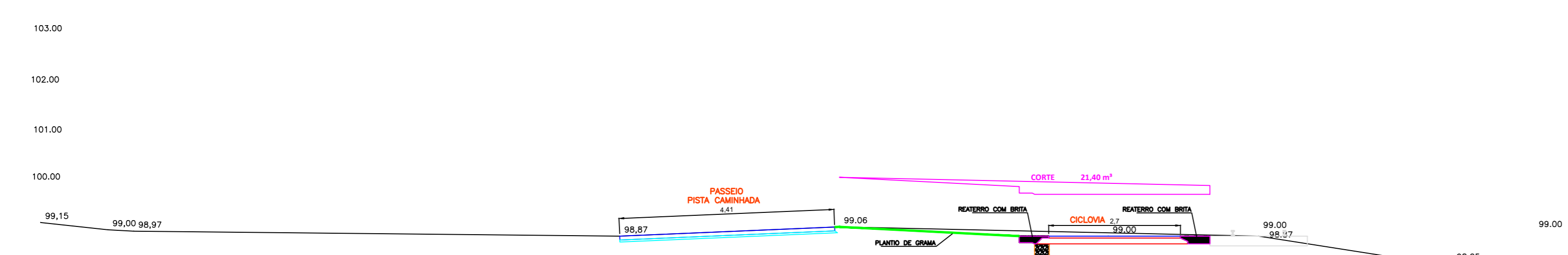

ESTACA 117

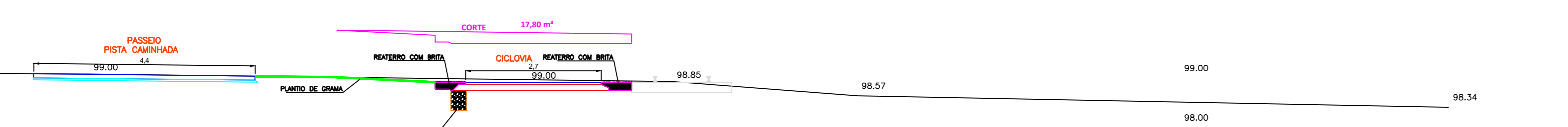

ESTACA 118

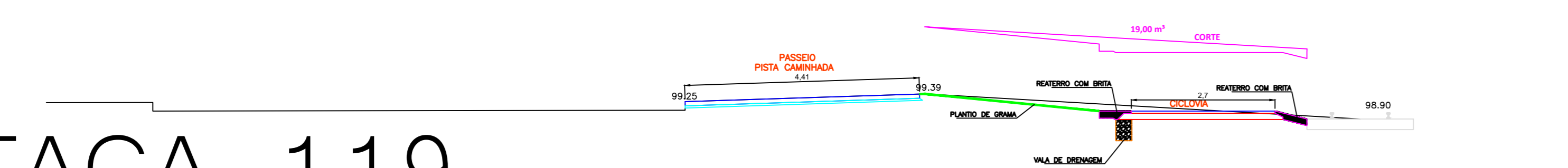

ESTACA 119

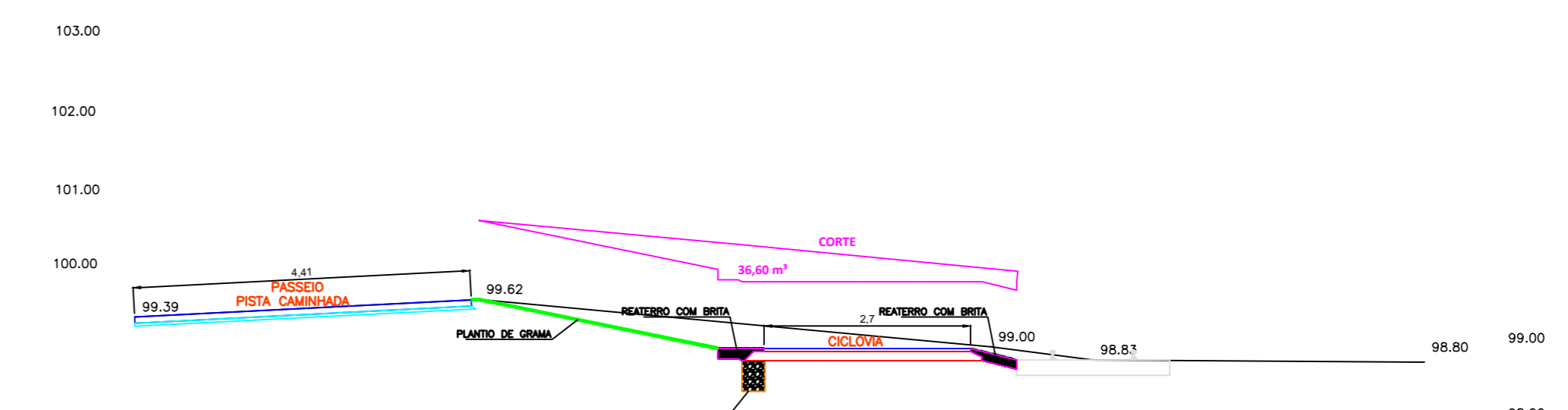

ESTACA 120

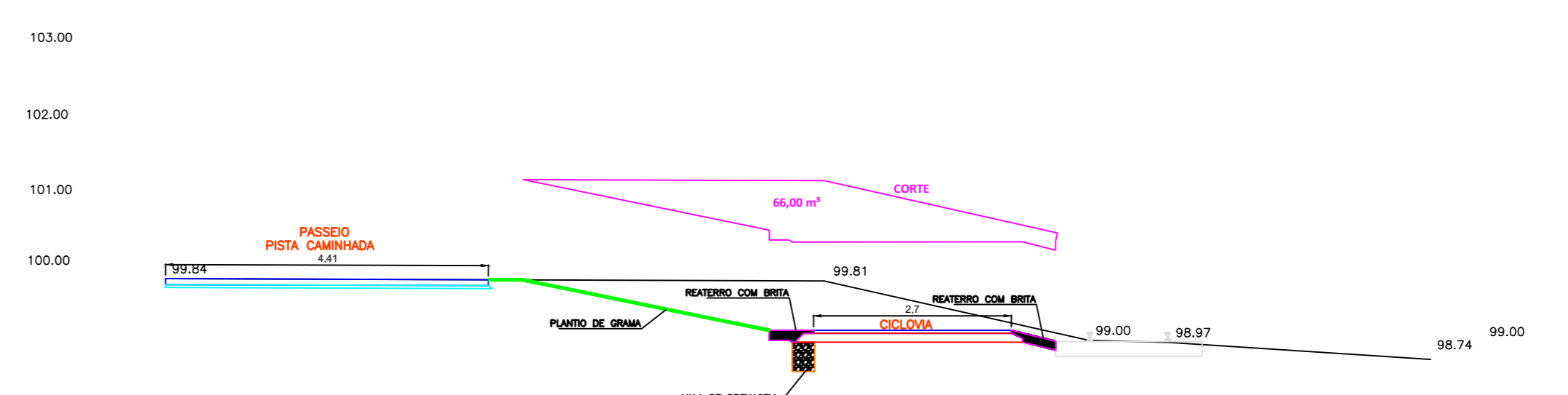

ESTACA 121

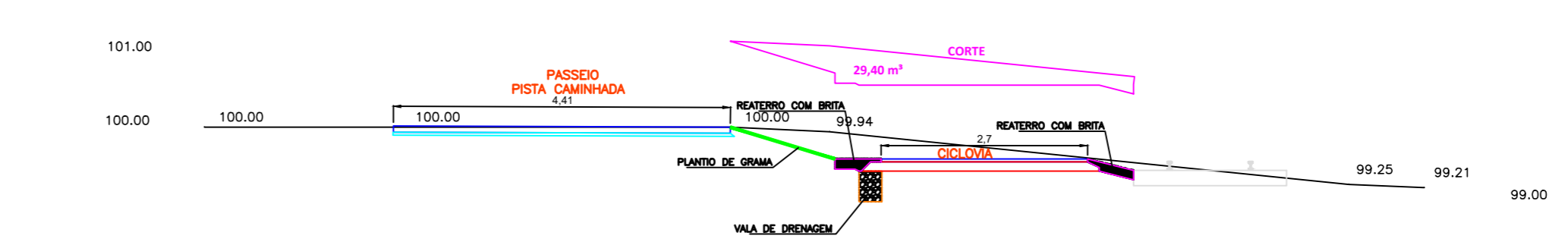

ESTACA 122

		ORÇAMENTO - PARQUE LINEAR - TRECHO 01
Referência: PARQUE LINEAR DE CAÇADOR LEVANTAMENTO DE SERVIÇOS TRECHO ESTACA 73 - 122 TRECHO - 03	FOLHA 11/17	Data 12 março 2020
Revisões: REVISÃO DO PROJETO	Área	Escala 1/75
Responsável Técnico EMERSON SCHMIDT - CREA 45145-D	Desenho EMERSON	Arquivo D:\Projeto\Parque Linear\PMCS\Capas\TRECHO 3.dwg

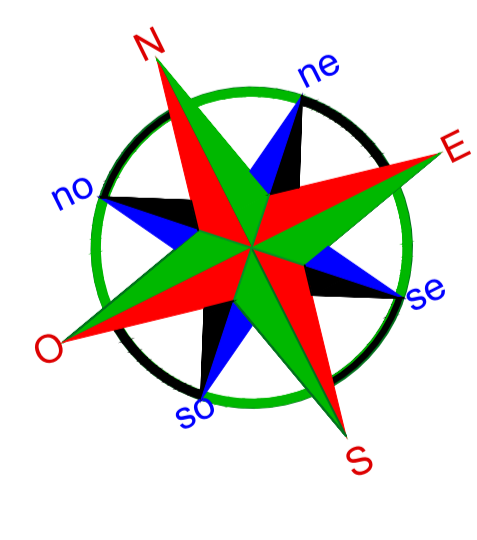
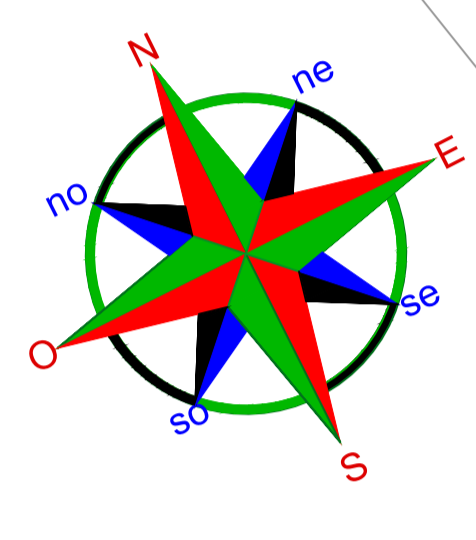
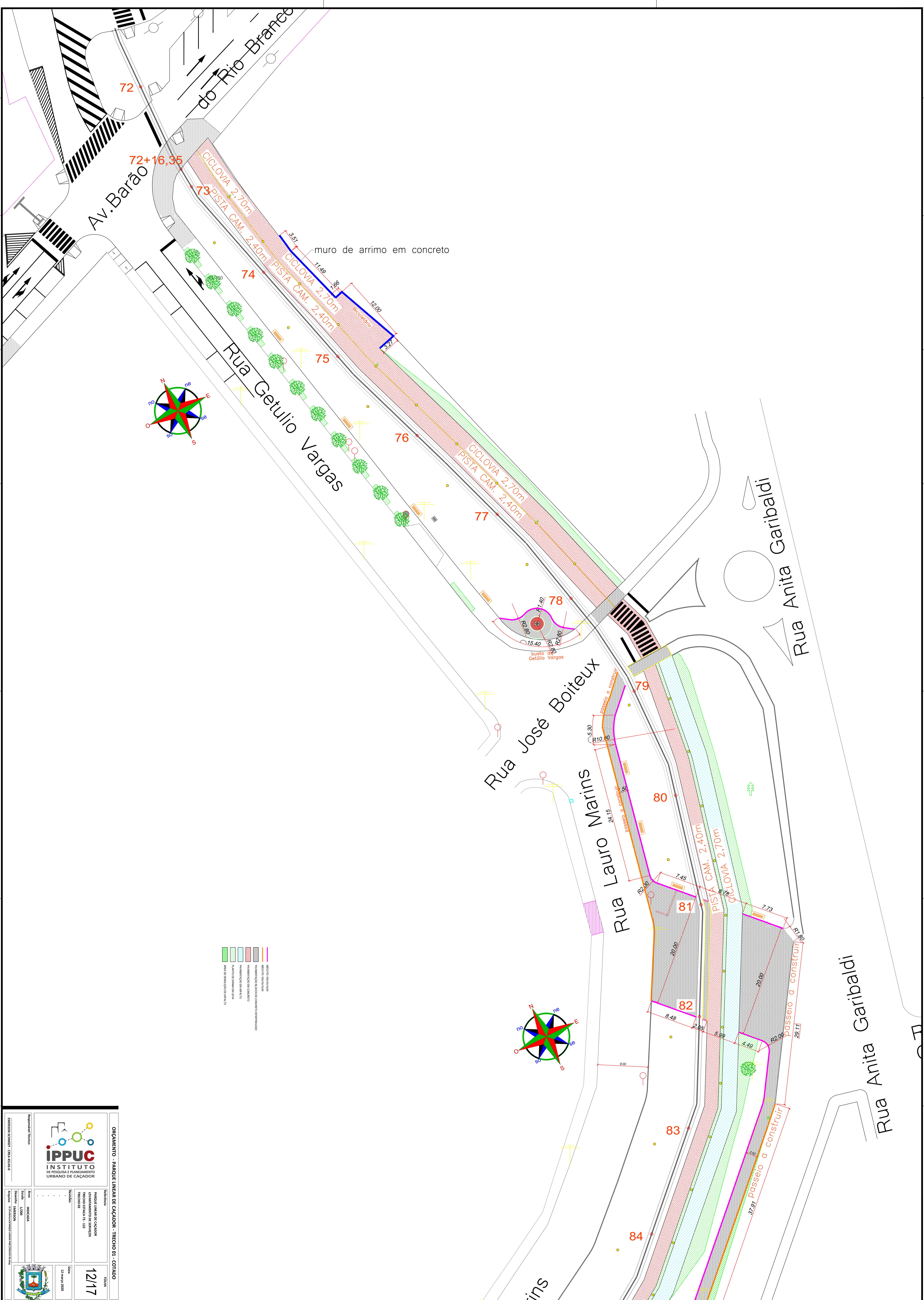

- ÁREA DE EMPLANTAMENTO
- PERÍMETRO DE PROTEÇÃO
- PERÍMETRO DE PROTEÇÃO
- PERÍMETRO DE PROTEÇÃO
- PERÍMETRO DE PROTEÇÃO
- PERÍMETRO DE PROTEÇÃO
- PERÍMETRO DE PROTEÇÃO

<p>IPPUC INSTITUTO DE PESQUISA E PLANEJAMENTO URBANO DE CAÇADOR</p>		<p>ORÇAMENTO - PARQUE LINEAR DE CAÇADOR - TRECHO 01 - COTADO</p>	
<p>Representante Técnico</p> <p>Nome: _____</p> <p>CPF: _____</p>	<p>Área</p> <p>12,00</p>	<p>Indicador</p> <p>12/17</p>	<p>Data</p> <p>12 maio 2020</p>
<p>Parque Linear de Caçador</p> <p>Exatidão dos Serviços</p> <p>Técnicos</p>		<p>12/17</p>	
<p>Projeto: _____</p>		<p>_____</p>	

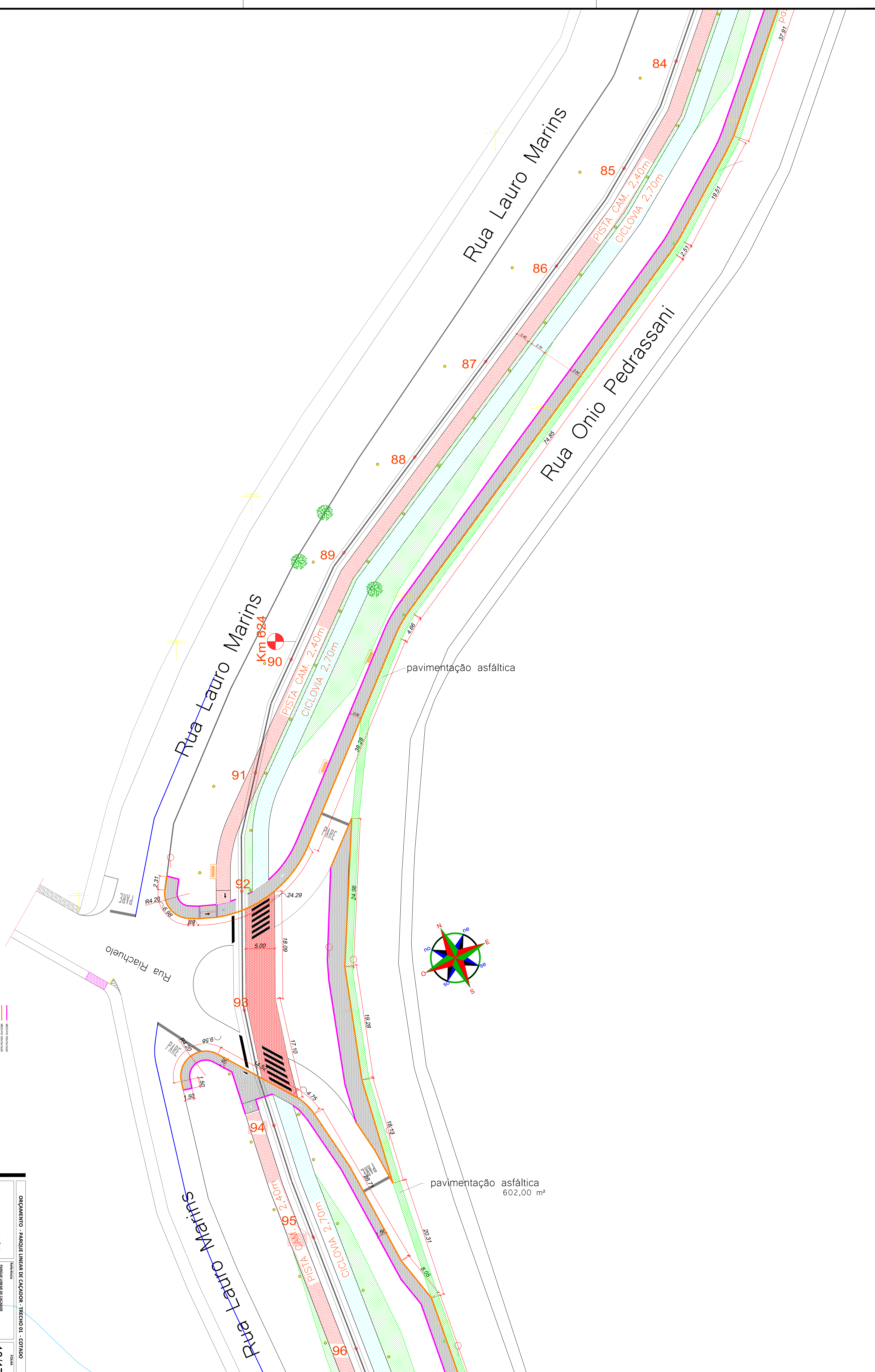

- ÁREA DE SINALIZAÇÃO VEICULAR
- PAVIMENTAÇÃO EM ASFALTO
- PAVIMENTAÇÃO EM CONCRETO
- PAVIMENTAÇÃO EM CIMENTO PORTLAND
- MÓDULO ORGANIZADO

IPPUC
INSTITUTO
DE PESQUISA E PLANEJAMENTO
URBANO DE CAÇADOR

ORÇAMENTO - PARQUE LINEAR DE CAÇADOR - TRECHO 01 - COTADO

PROJETO	PARQUE LINEAR DE CAÇADOR - EXPERIMENTAÇÃO DE SERVIÇOS URBANOS
FECHA	12/200
INDICADA	13/17
ELABORADO	12/200
APROVADO	12/200

FOLHA 13/17
12 de março 2020

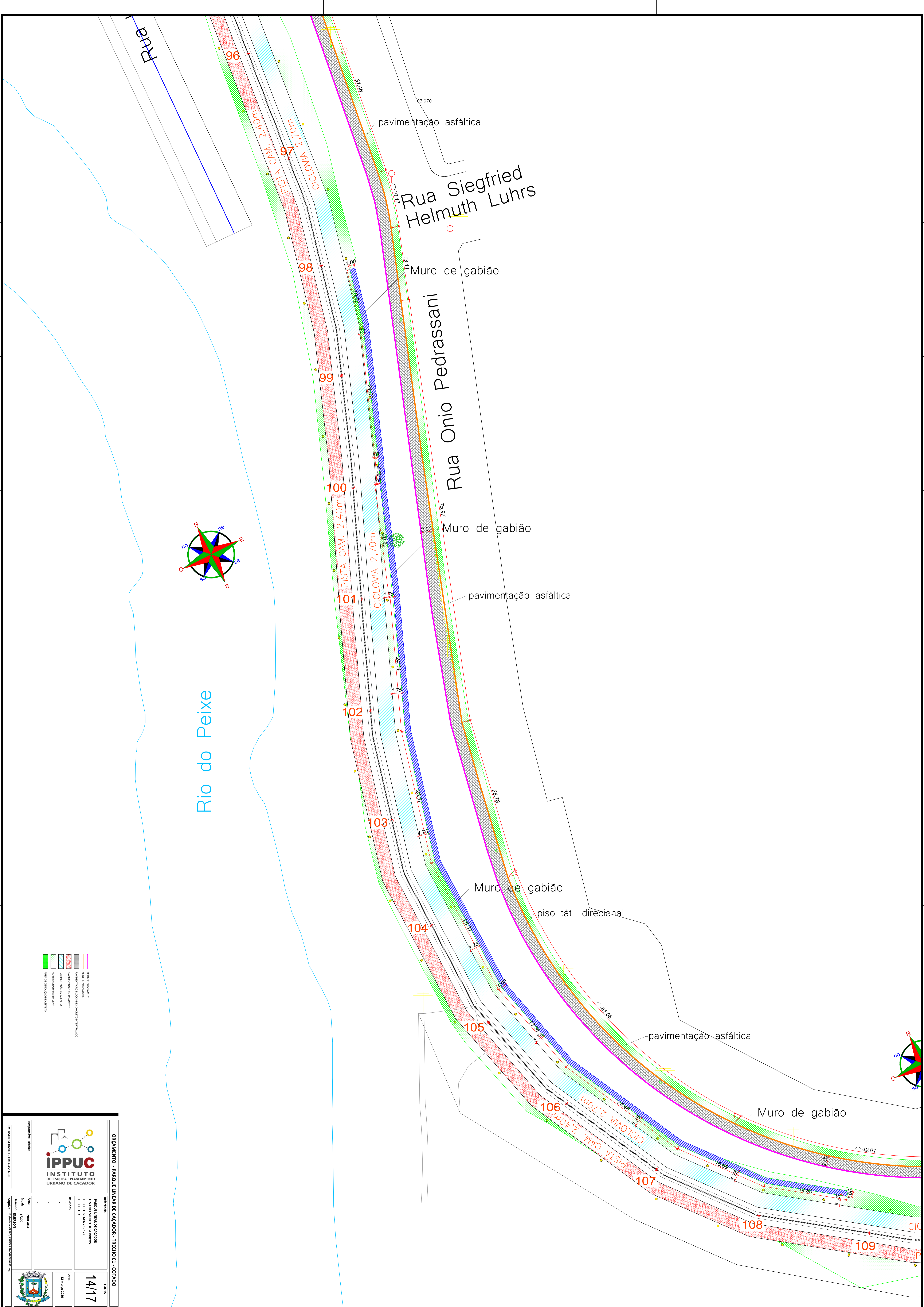

Rua Onio Pedrassani

Rua Siegfried Helmuth Luhrs

Rua Onio Pedrassani

Rio do Peixe

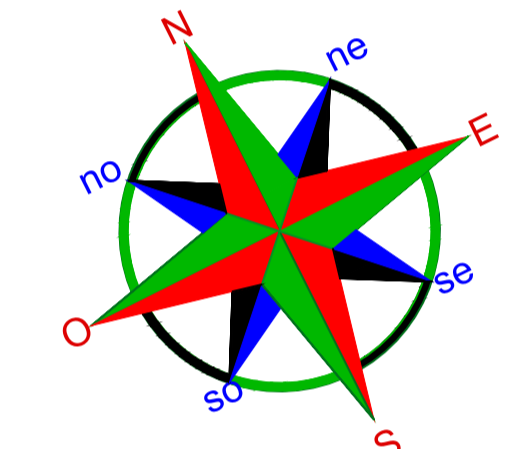

- Muro de gabião
- Pavimentação asfáltica
- Piso tátil direcional
- Ciclovia 2,70m
- Pista CAM 2,40m
- Área de drenagem

IPPUC
INSTITUTO
DE PESQUISA E PLANEJAMENTO
URBANO DE CAÇADOR

ORÇAMENTO - PARQUE LINEAR DE CAÇADOR - TRECHO 01 - COTADO

Representante Técnico	
Título	PARQUE LINEAR DE CAÇADOR - EXPERIMENTAIS SERVIÇOS - TRECHO 01
Escala	1:200
Data	14/17
Arquiteto	12 maio 2020

MURO DE CONTENÇÃO EM GABIÃO

ESTACA 98 +1,80m ATÉ 102
ESTACA 107 ATÉ 108

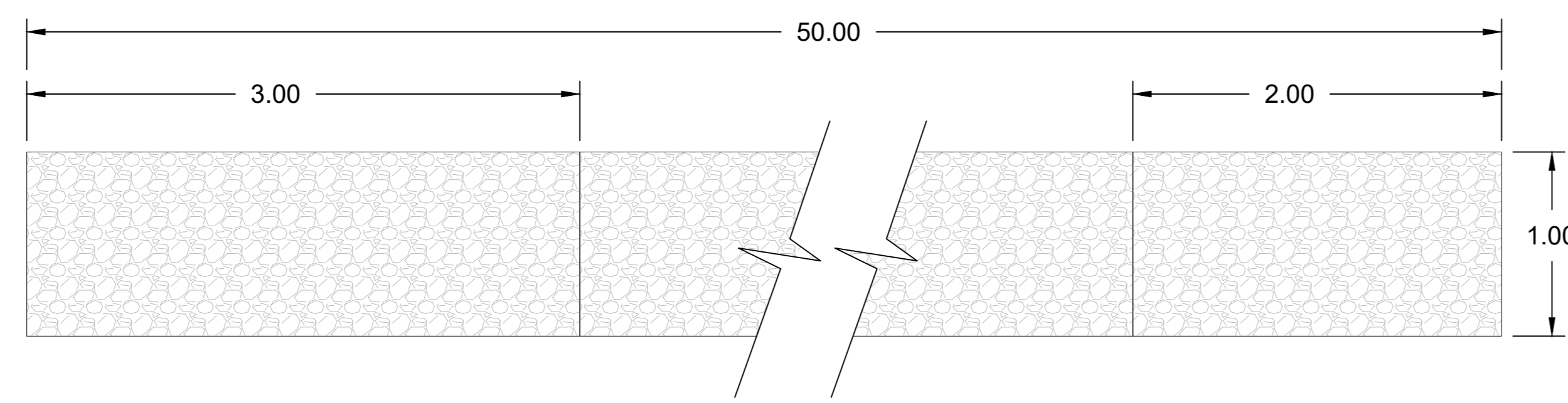
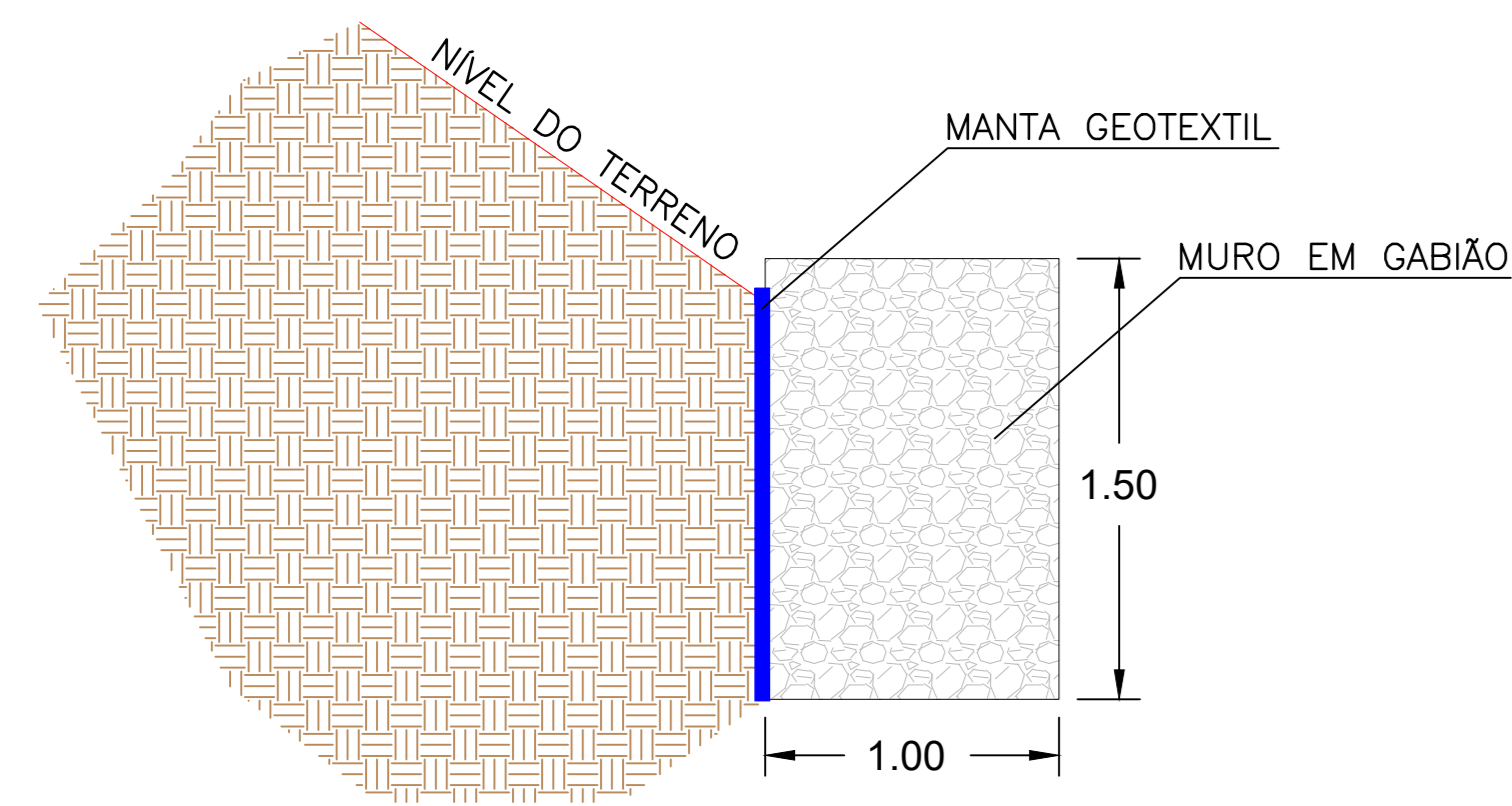

ESTACA 102

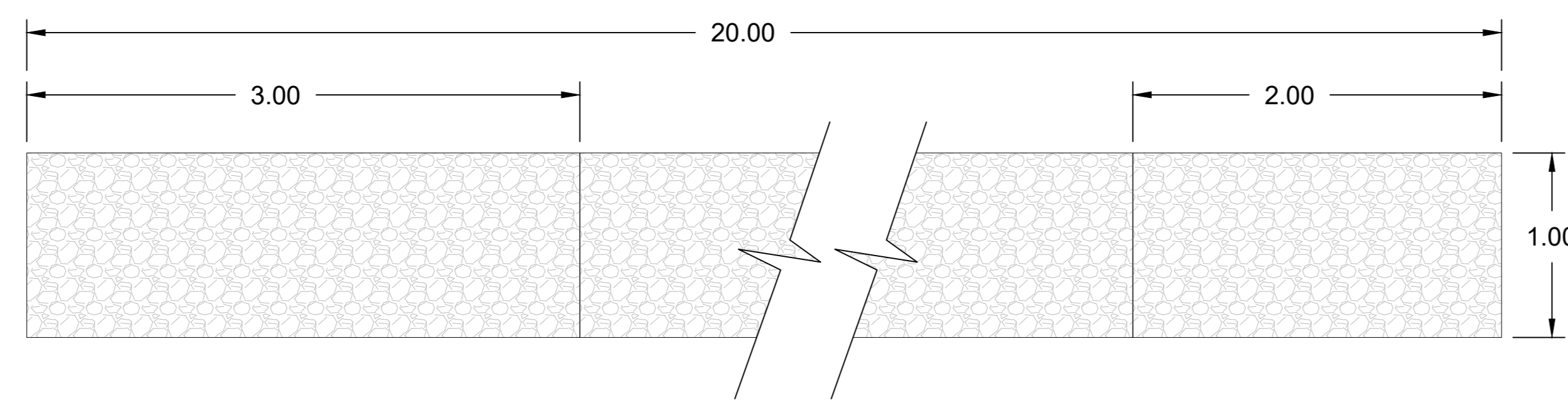
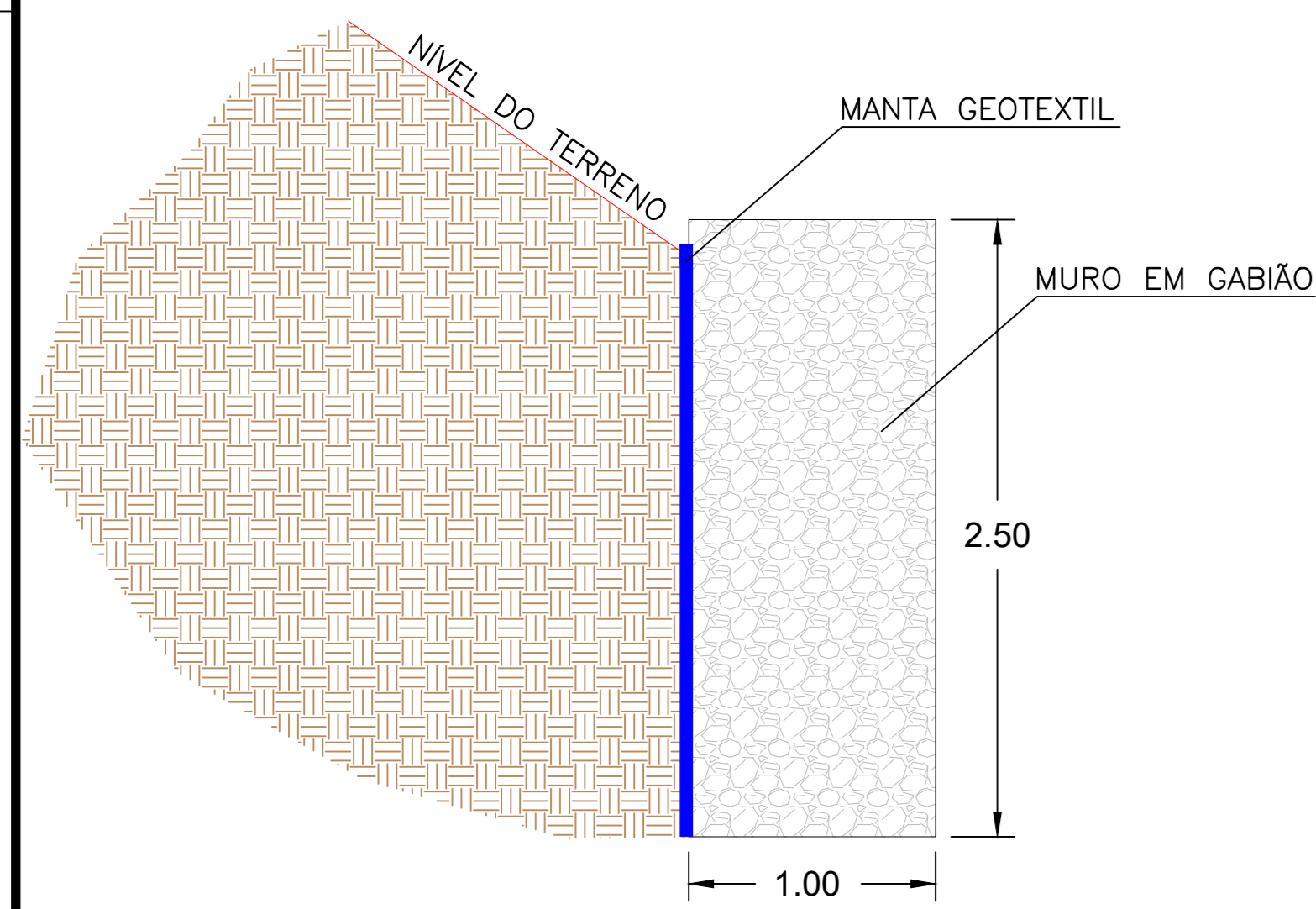

ESTACA 103 ATÉ 104
ESTACA 106

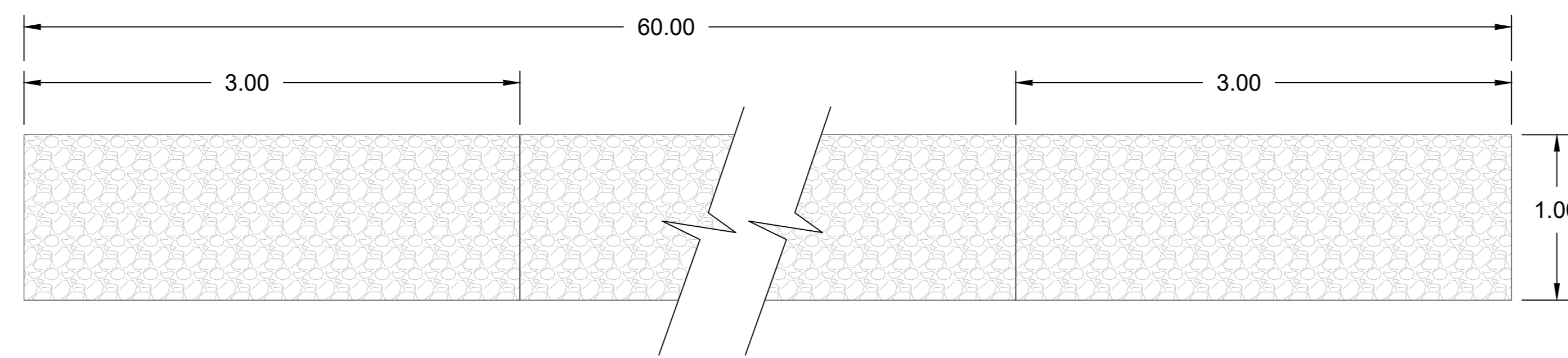
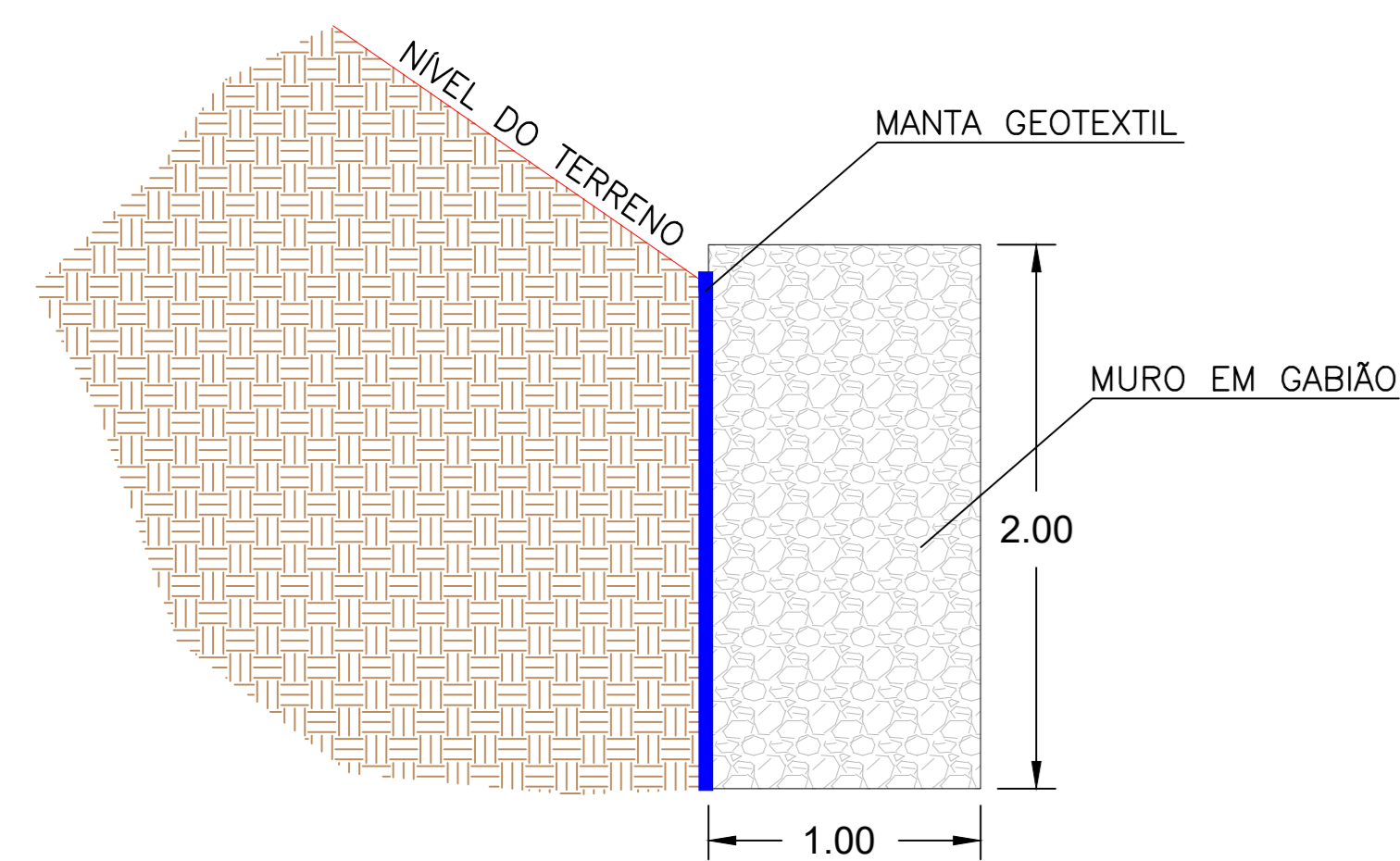

ESTACA 105

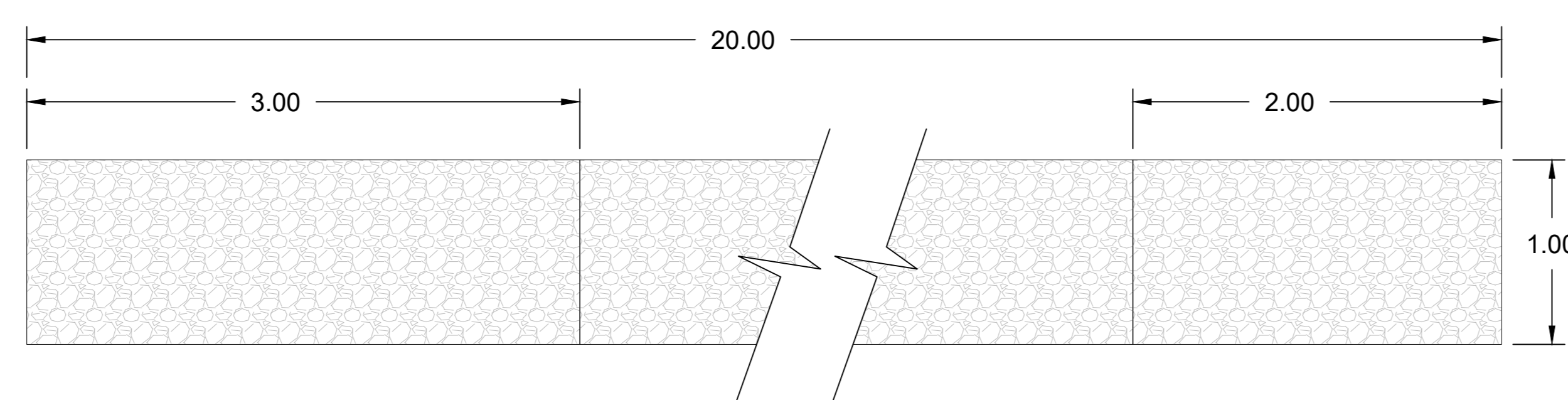
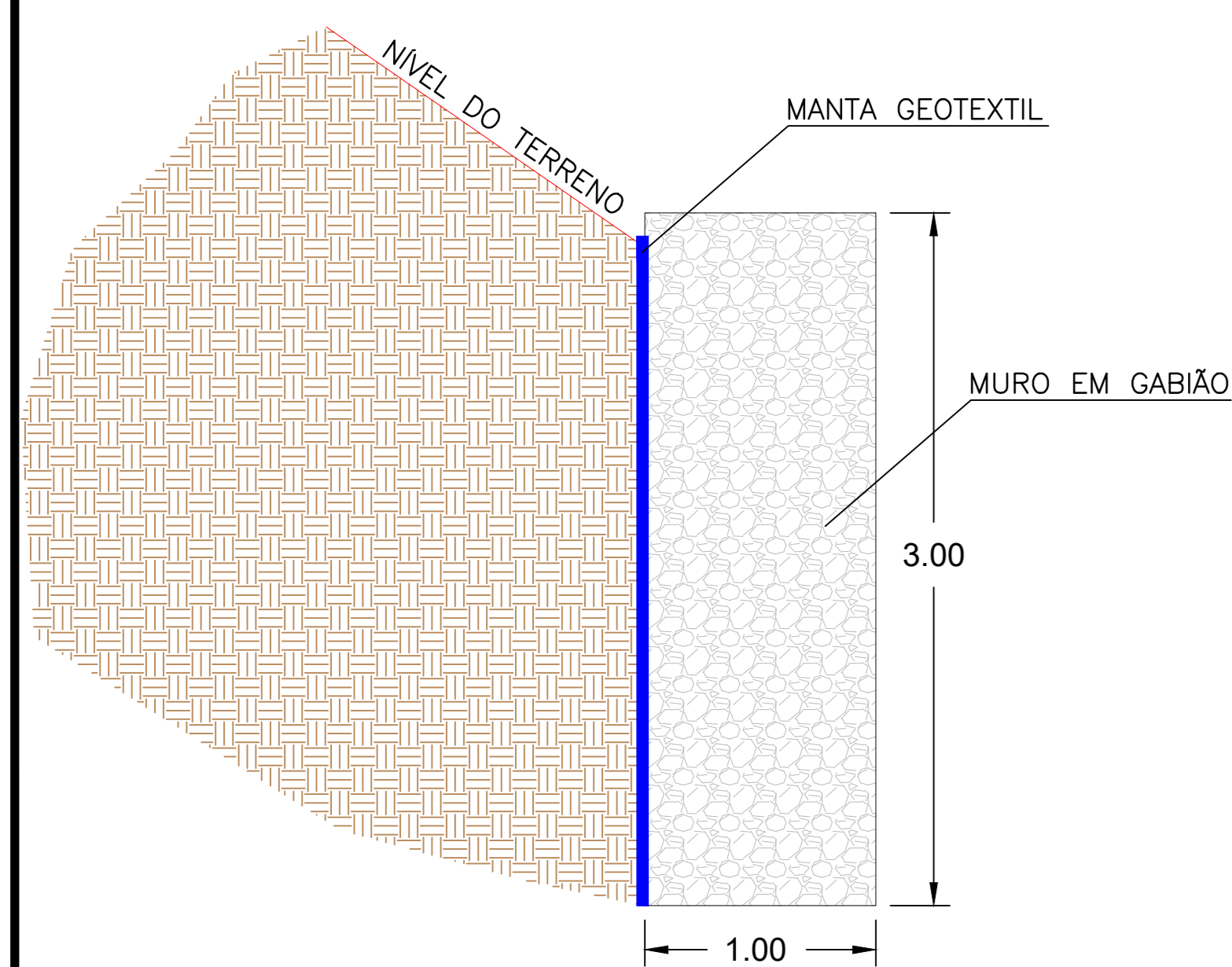

LIGAÇÃO DRENAGEM - TUBULAÇÃO

MURO DE ARRIMO EM CONCRETO ARMADO

ESC. 1/15

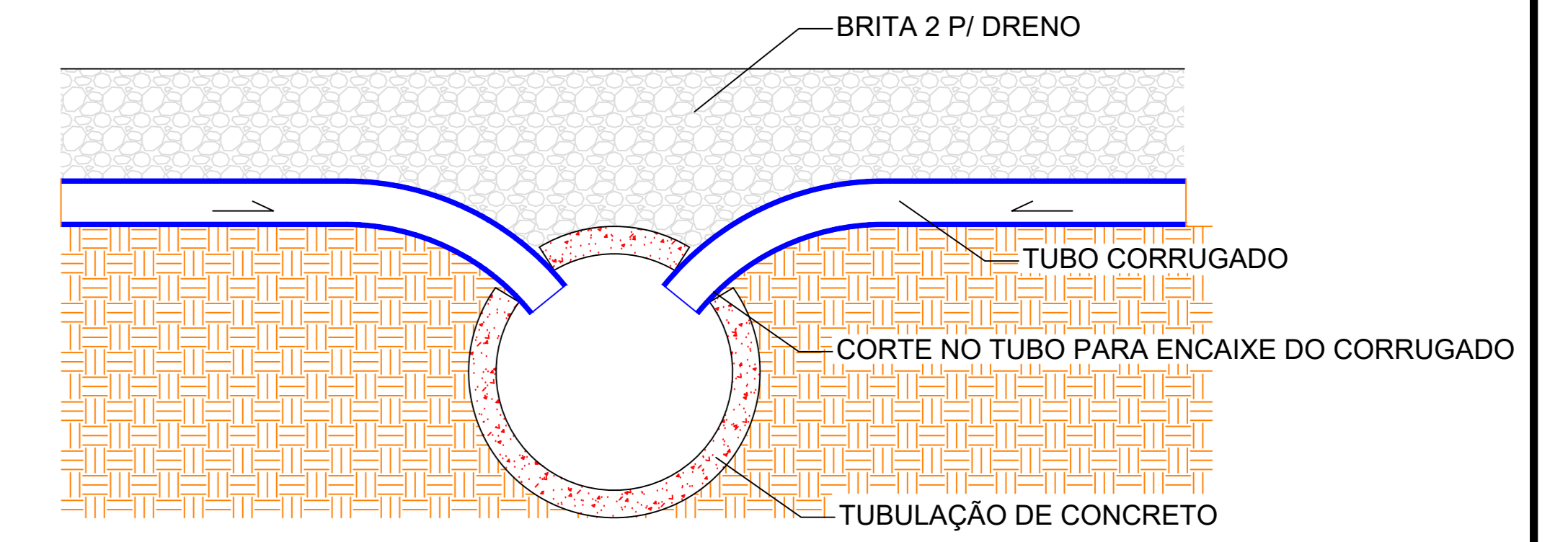
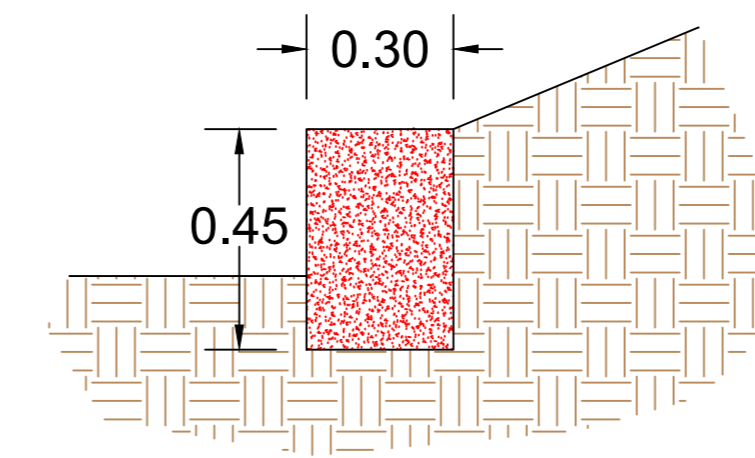

DETALHE DA BOCA DE LOBO

ESC. 1/15

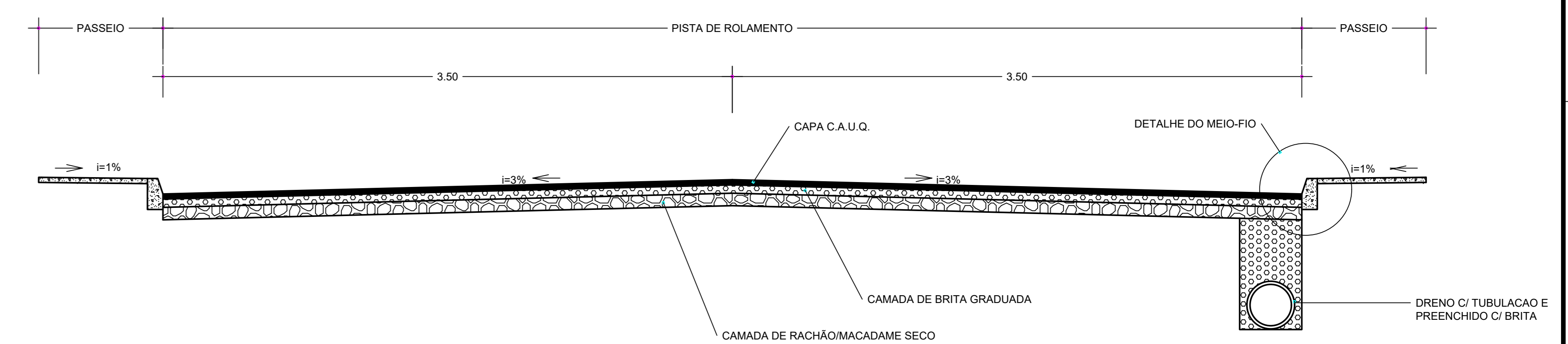
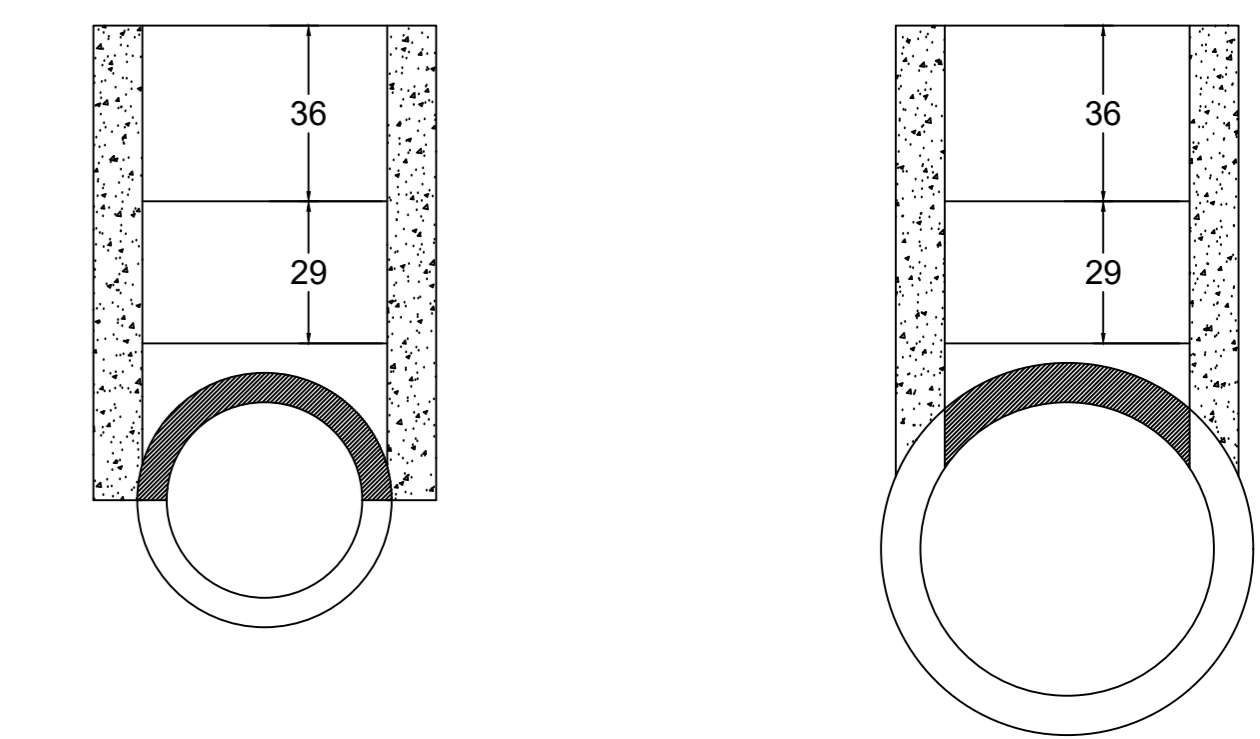
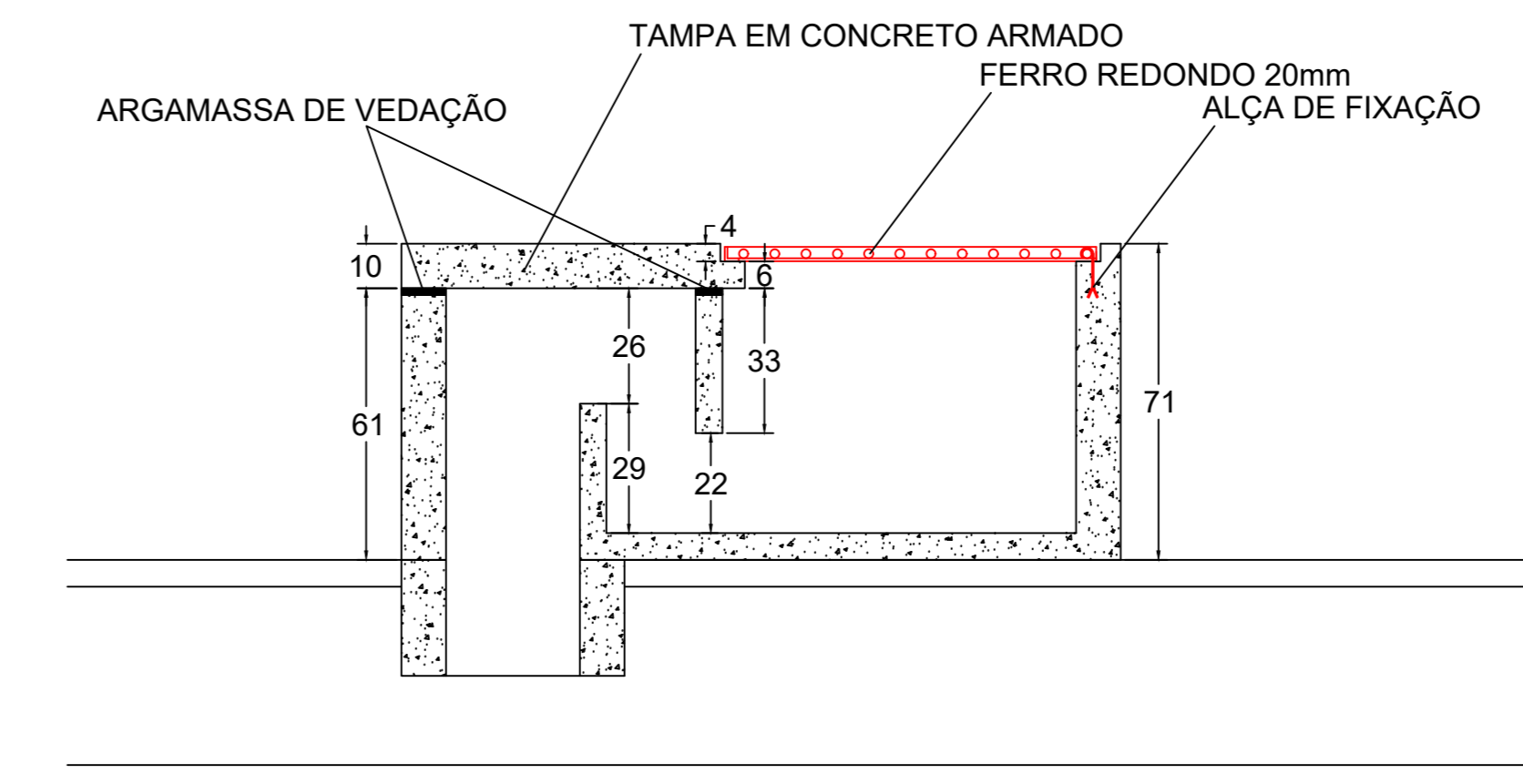
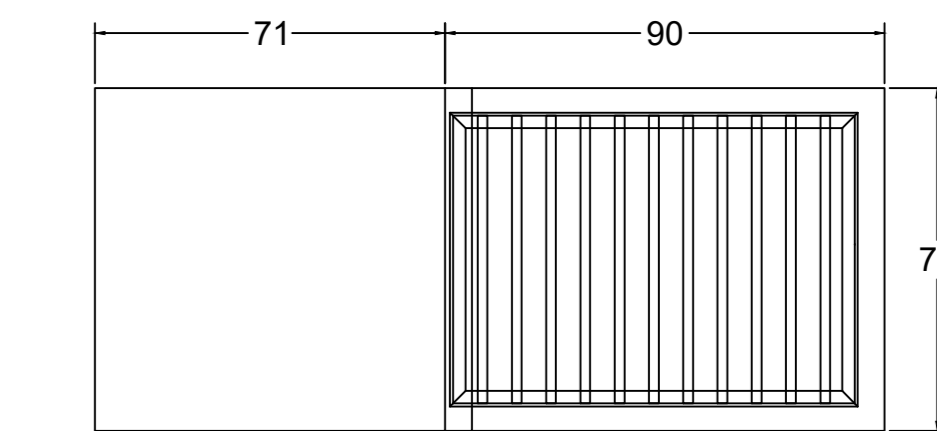
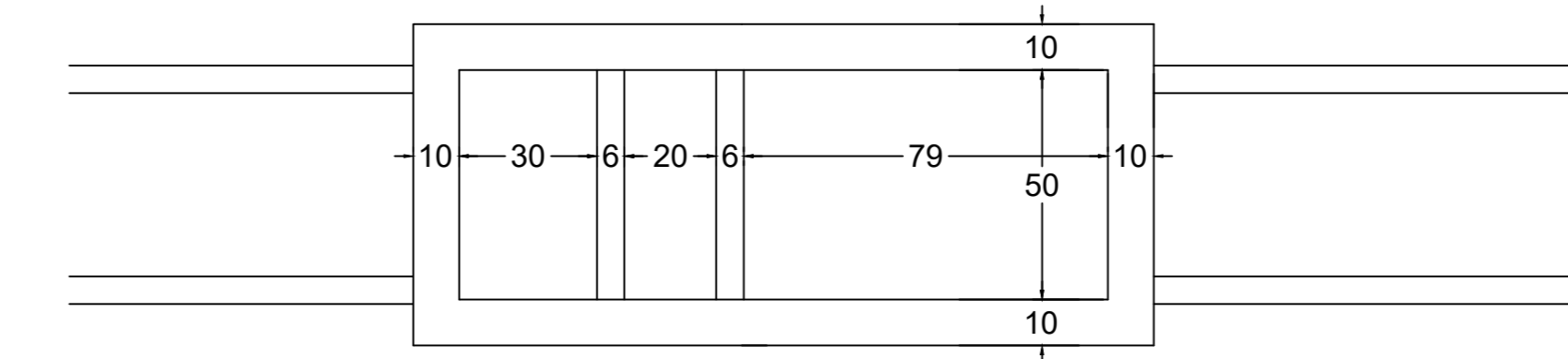

SEÇÃO TRANSVERSAL SEM ESCALA

GEOMÉTRICO - PARQUE LINEAR DE CAÇADOR		FOLHA
Referência	PARQUE LINEAR DE CAÇADOR DETALHES MUIROS, PAVIMENTO, BOCA DE LOBO TRECHO ESTACA 73 - 122 TRECHO 03	17/17
Revisões		Data
		12 março 2020
Responsável Técnico	Área INDICADA	
	Escala 1/25	
Desenho EMERSON	Arquivo	
EMERSON SCHMIDT - CREA 45145-0	© Instituto de Pesquisa e Planejamento Urbano de Caçador	